



Phone (410) 820-5111
Toll Free(800) 626-7713
Fax (410) 822-9633

Ohmic Instruments
3081 Elm Point Industrial Dr.
St. Charles, MO 63301

www.ohmicinstruments.com
Sales: sales@ohmicinstruments.com
Service: service@ohmicinstruments.com

IC HUMIDITY SENSOR - HC-610

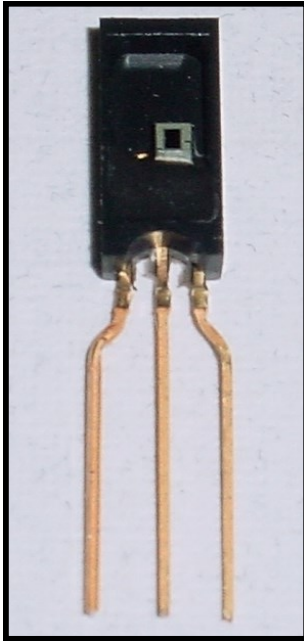

- **Thermoset Polymer Capacitive Humidity Sensor**
- **New Plastic Packaging**
- **Better Handling Protection**
- **Linear DC Voltage Output**
- **Provides Better Environmental Resistance**
- **Fast Response Time**
- **Chemically Resistant**
- **Stable, Low Drift Performance**
- **Recovers From Condensation And Wetting**

HUMIDITY SENSOR & SIGNAL CONDITIONER IN A MINI-PACKAGE

Model HC-610 humidity sensor is designed for OEM's requiring miniature sensing elements that can be easily integrated into electronic products with a high degree of accuracy and repeatability.

The sensor utilizes a laser trimmed thermoset polymer capacitive sensing element with on-chip integrated signal conditioning. The sensor's construction provides excellent resistance to wetting, dust, dirt, oils, and common environmental chemicals. A CMOS signal conditioning circuit provides a linear voltage output over the full range of 0-100% RH. The accuracy is $\pm 2\%$ RH with 0.5% repeatability and 5% interchangeability.

These sensors provide a 0.63 to 3.12 Vdc signal output when 4 Vdc is supplied or .92 to 4.52 Vdc when 5.8

Vdc is supplied. Current consumption is 200 μ A at 5 Vdc. Special packaging consisting of a plastic assembly with a teflon filter is available for the HC-610.

The sensor's linear voltage output makes direct input into a controller or other device possible. Certification to NIST traceable standards is available.

The HC-610 sensor has an operating temperature range of -40 to +185°F. The sensor's design provides better resistance to condensation and chemical vapors, such as organic solvents, chlorine, and ammonia. The sensor may be cleaned with isopropyl alcohol.

Applications include HVAC, refrigeration, industrial dryers, appliances, humidistats, weather telemetry and battery-powered systems.

WARRANTY: All products manufactured by OHMIC Instruments are warranted to be free of defects in material and workmanship for one year after delivery. Any equipment found to be defective within this period will be repaired or replaced free of charge.

SPECIFICATIONS: MODEL HC-610

Response Time	15 Seconds in slow moving air @ 25°C
Stability	± 1% RH Typ. at 50% RH In 5 Years
Total Accuracy	± 2% RH, 0-100% RH non-condensing @ 25°C
Interchangeability	± 5% RH
Operating Temperature	-40 to +85°C (-40 to +185°F)
Hysteresis	± 1.2% of Span Maximum
Linearity	± 0.5% RH Typical
Repeatability	± 0.5% RH
Voltage Supply (Vps)	4.0– 5.8 Vdc regulated
Voltage Output	$V_{out} = V_{ps} (0.0062 (\text{Sensor RH}) + . 16)$
RH Out	$\%RH = (((6.3 \times V_{out}) \div V_{ps}) - 1) \times 25.6$
Temperature Compensation	True RH = $\%RH \div (1.0546 - 0.00216T)$ where T= °C and %RH = Uncorrected % RH
Drive Capability	50µA typical, 20 µA minimum, 100 µA maximum
Turn-on Time	≤ 0.1 second
Current Requirement	200 µ A @5 Vdc Regulated
Handling/Installation	Electrostatic Sensitive. Protected to 15 KV Max. Shade from Intense Light

Mounting Dimensions for reference only: mm (in.)

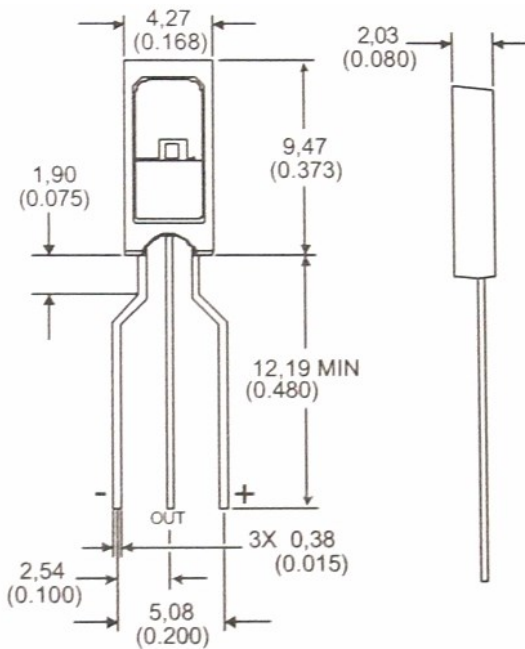

Temperature Compensation

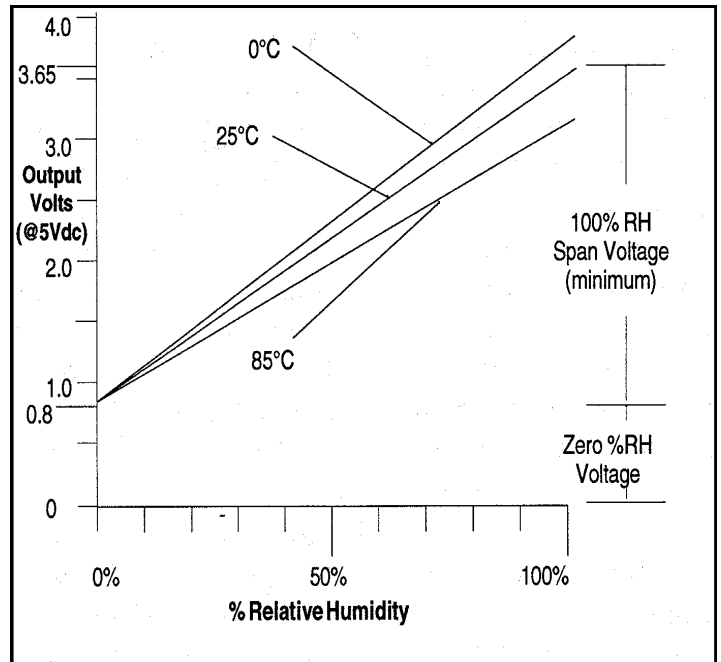

ENGINEERING SUPPORT: OHMIC Instruments designs and manufactures a full line of environmental and bio-medical sensor, instruments and controls. Many of our products are custom designed to meet specific requirements. Our engineers will be pleased to discuss your application.



Phone (410) 820-5111
Toll Free(800) 626-7713
Fax (410) 822-9633

Ohmic Instruments
3081 Elm Point Industrial Dr.
St. Charles, MO 63301

www.ohmicinstruments.com
Sales: sales@ohmicinstruments.com
Service: service@ohmicinstruments.com