

COST CODE PRJ1000854 APS03-132_PH01 General_APS03071702: 8-ID-E Operations

QTY - 1

MIKE FISHER 2-1576

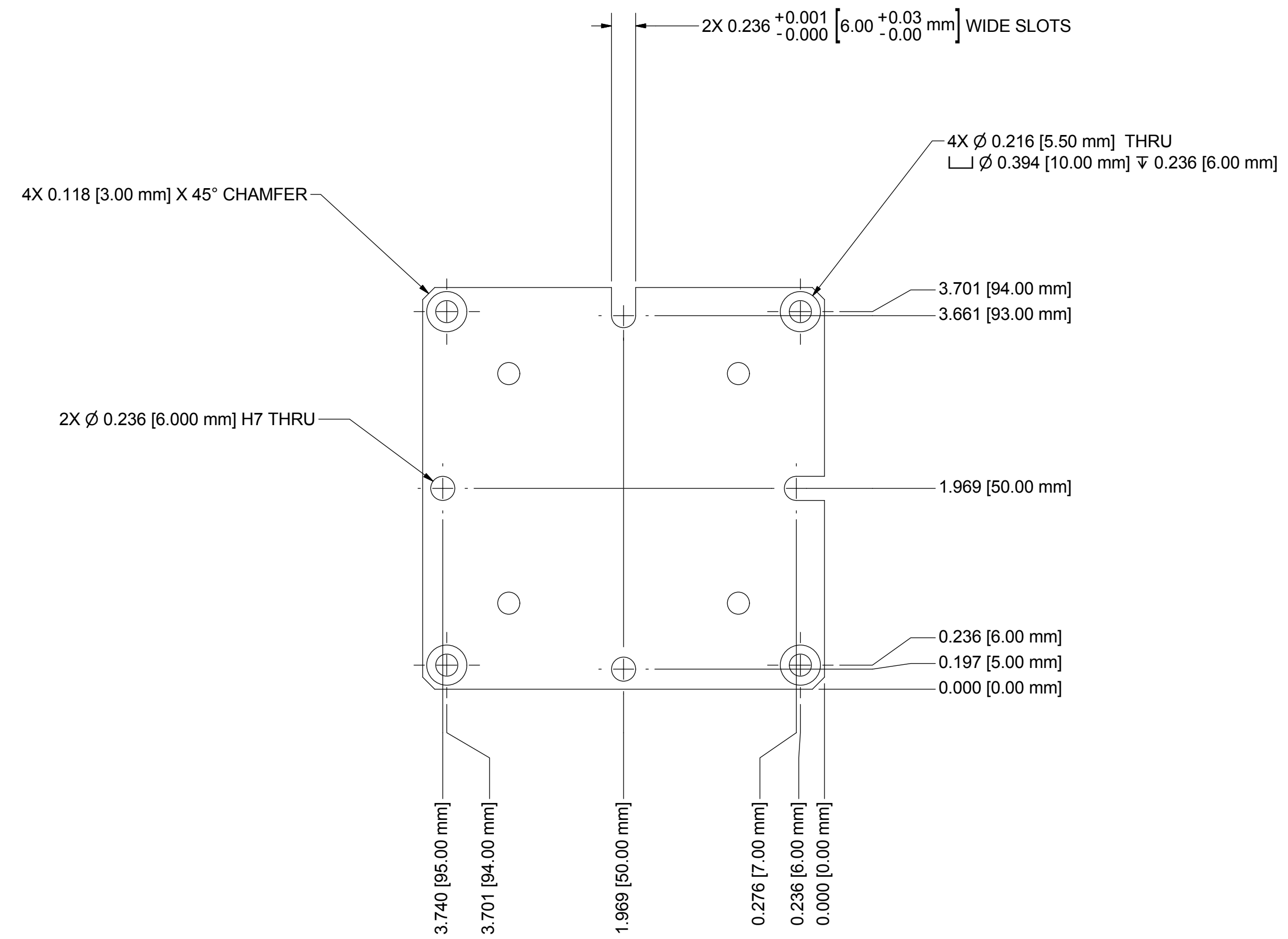
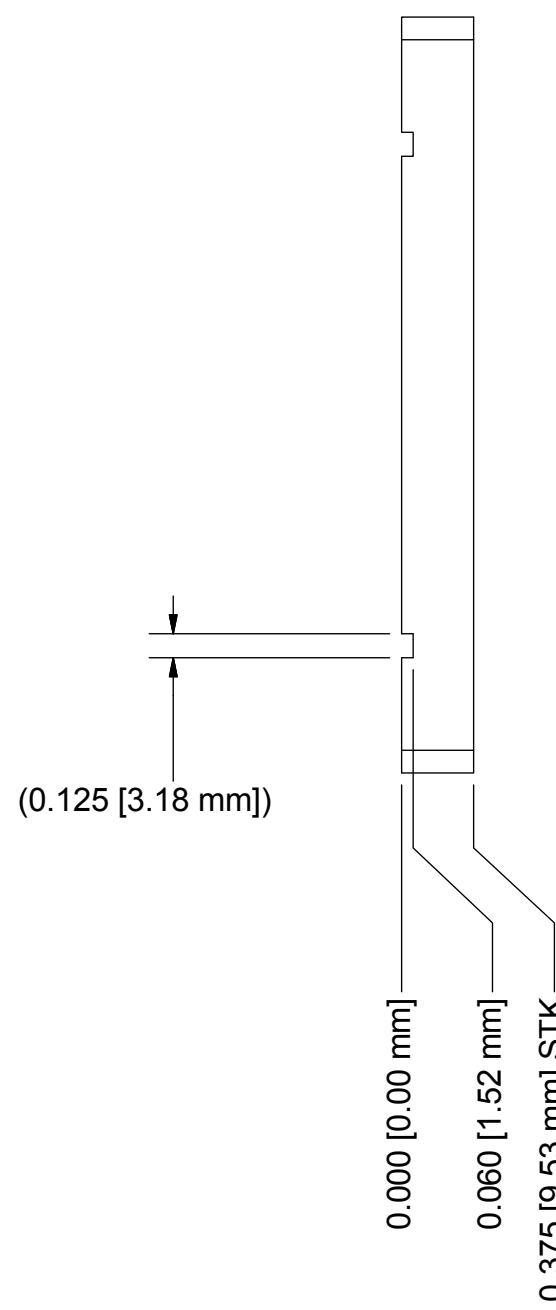
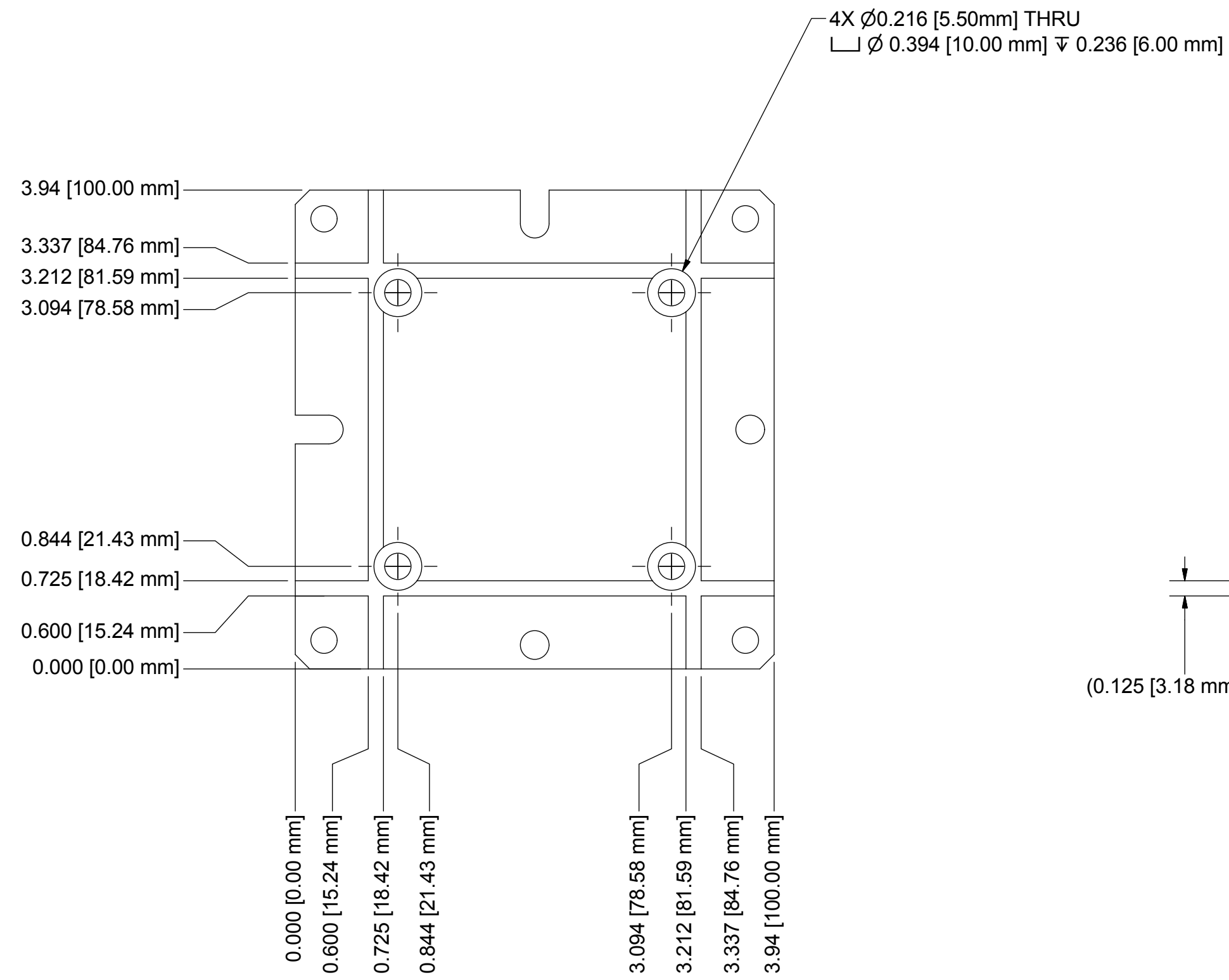
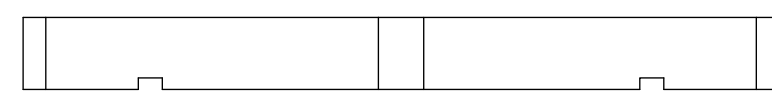
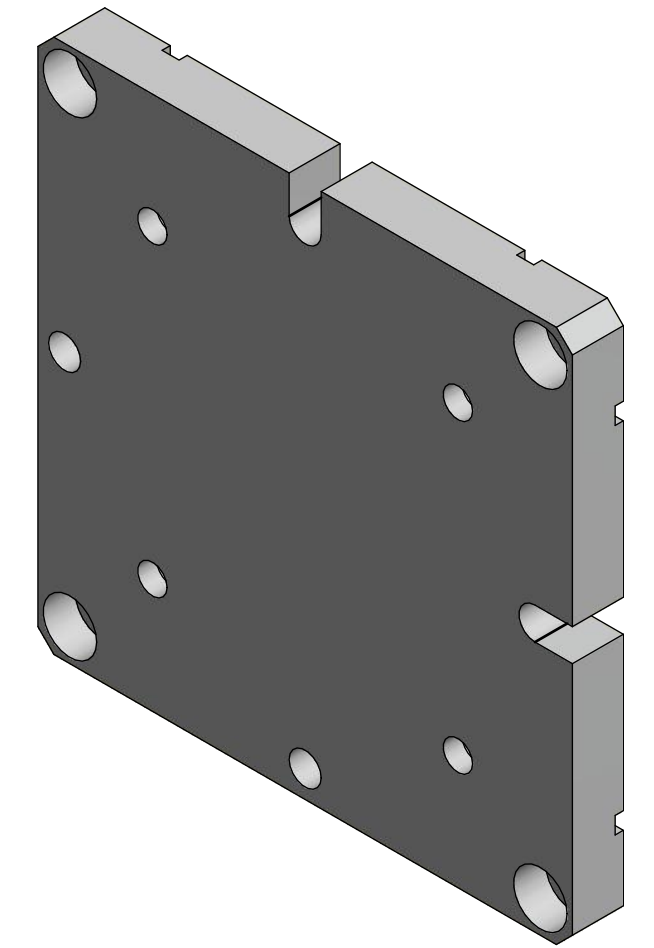
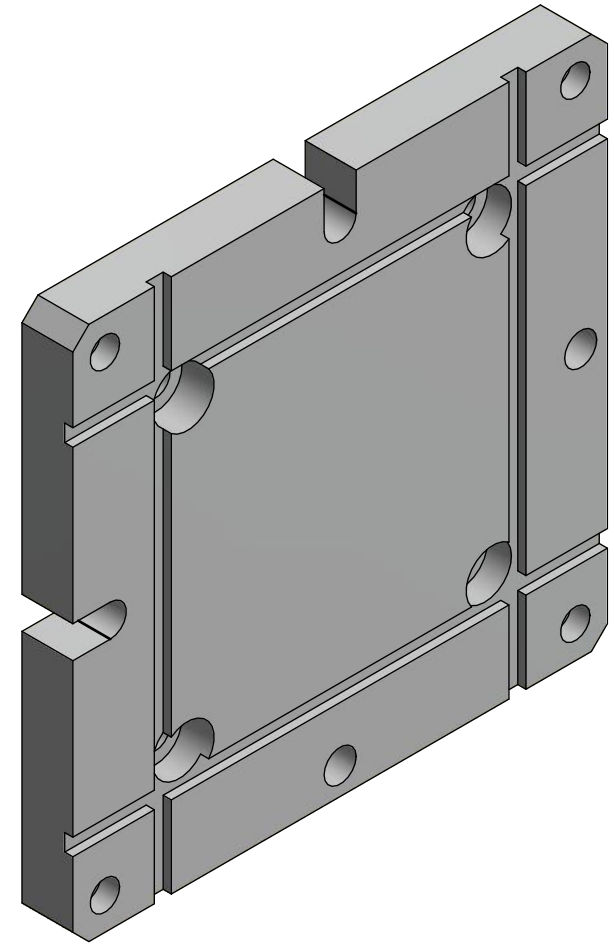

	DRAWN: MVF	MATERIAL: Aluminum 6061	ESTIMATED MASS: N/A
	CHKD:	SIMILAR TO:	
ANSI Y14.5-2009 APPLIES	APPRD:	APS 8-ID GISX SAMPLE ENVIRONMENT UPGRADE	
EXCEPT AS NOTED:	SHEET:	1 OF 1	
UNITS ARE: INCHES	LOWER ADAPTOR PLATE FOR LINKAM STAGE		
SURFACE FINISH: 125			
3 PLACE DECIMAL ± 0.005	SCALE 2:1	FIRST USED ON	DWG NO
2 PLACE DECIMAL ± 0.015	DATE 12/11/2017	GISX-325	GISX-326
1 PL DEC, FRAC. $\pm 0.030, 1/32$			SIZE D
ANGULAR TOLS. ± 0.5			REV

CHANGE LETTER	CHGD BY	CHKD BY	DATE	CHANGE
---------------	---------	---------	------	--------