

COST CODE PRJ1000854 APS03-132_PH01
 General_APS03071702: 8-ID-E Operations

QTY - 1

MIKE FISHER 2-1576

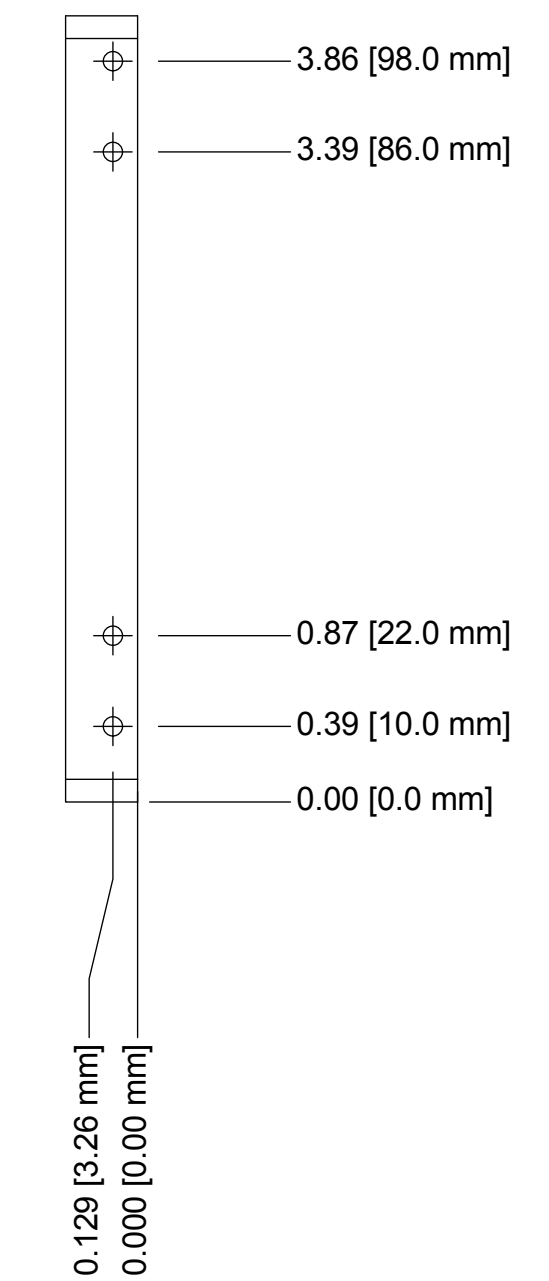
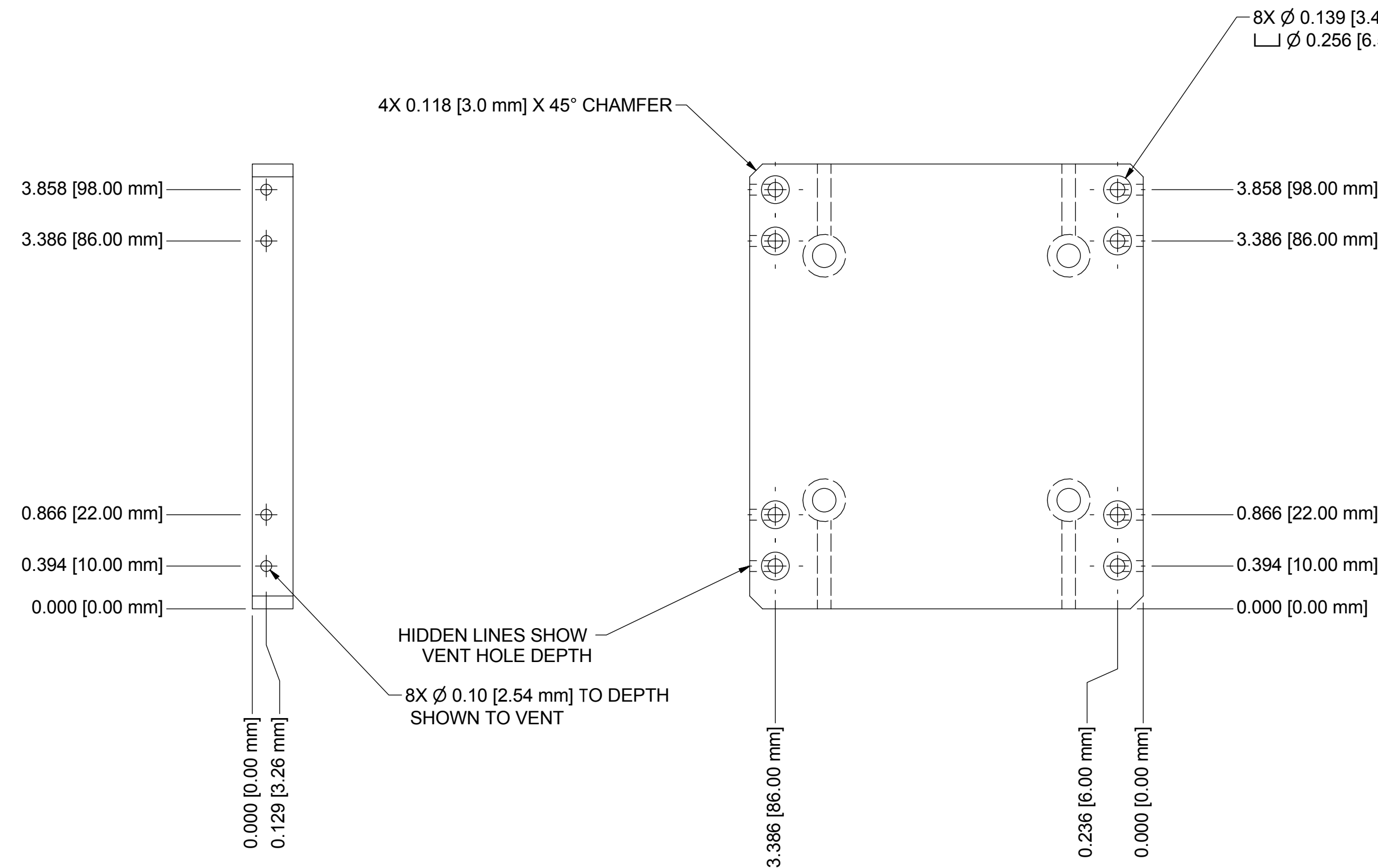
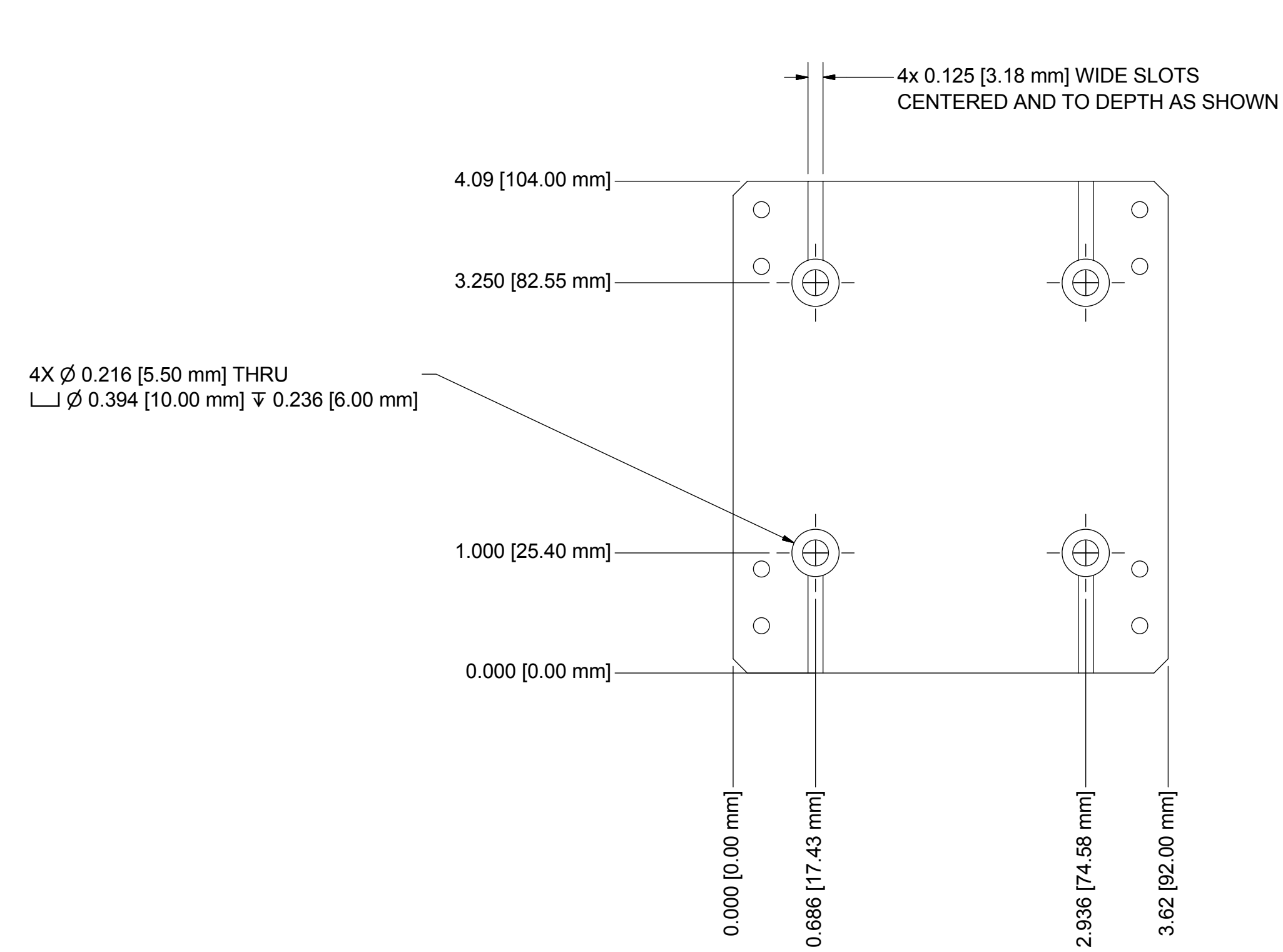
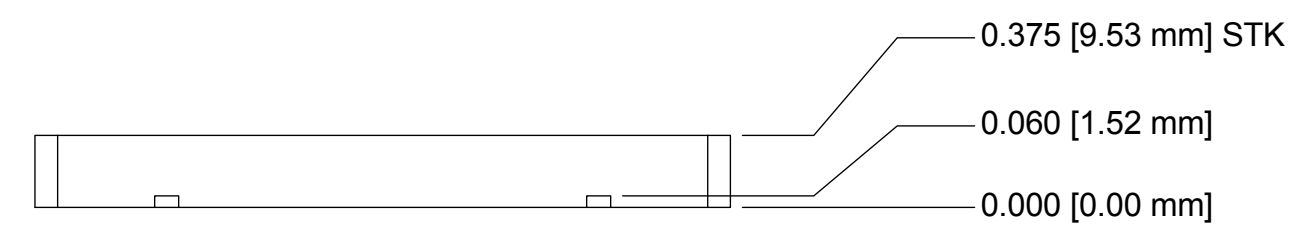
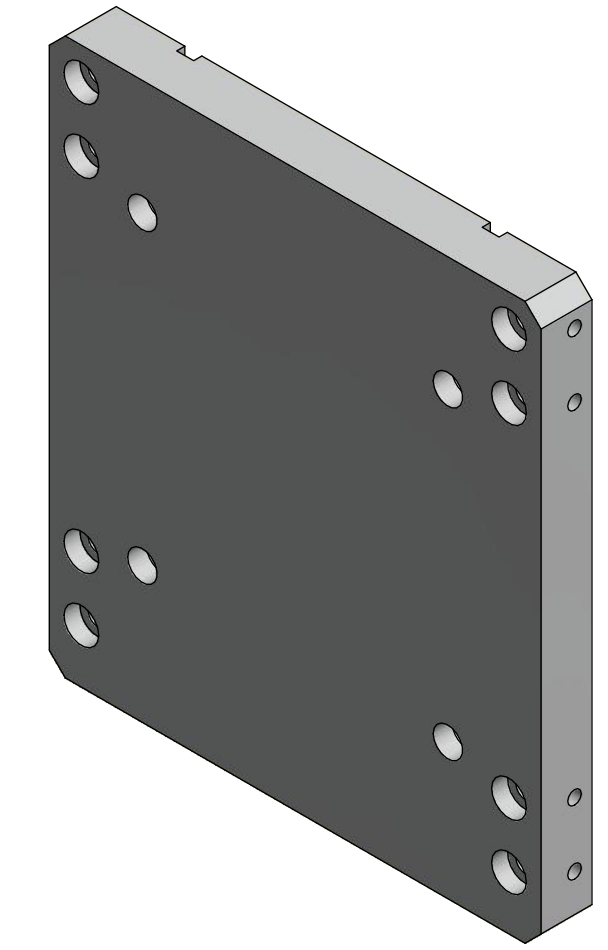

	DRAWN: MVF	MATERIAL: Aluminum 6061	ESTIMATED MASS: N/A
	CHKD:	SIMILAR TO:	
ANSI Y14.5-2009 APPLIES	APPRD:	APS 8-ID GISX SAMPLE ENVIRONMENT UPGRADE	
EXCEPT AS NOTED: UNITS ARE: INCHES	SHEET:	UPPER ADAPTOR PLATE FOR LINKAM STAGE	
SURFACE FINISH: 125 ✓	1 OF 1		
3 PLACE DECIMAL \pm 0.005 2 PLACE DECIMAL \pm 0.015 1 PL. DEC. FRAC. \pm 0.030, 1/32 ANGULAR TOL'S \pm 0.5	SCALE 2:1	FIRST USED ON	DWG NO
	DATE 12/11/2017	GISX-325	GISX-328
			SIZE D
			REV

CHANGE LETTER	CHGD BY	CHKD BY	DATE	CHANGE