

SECTION A-A

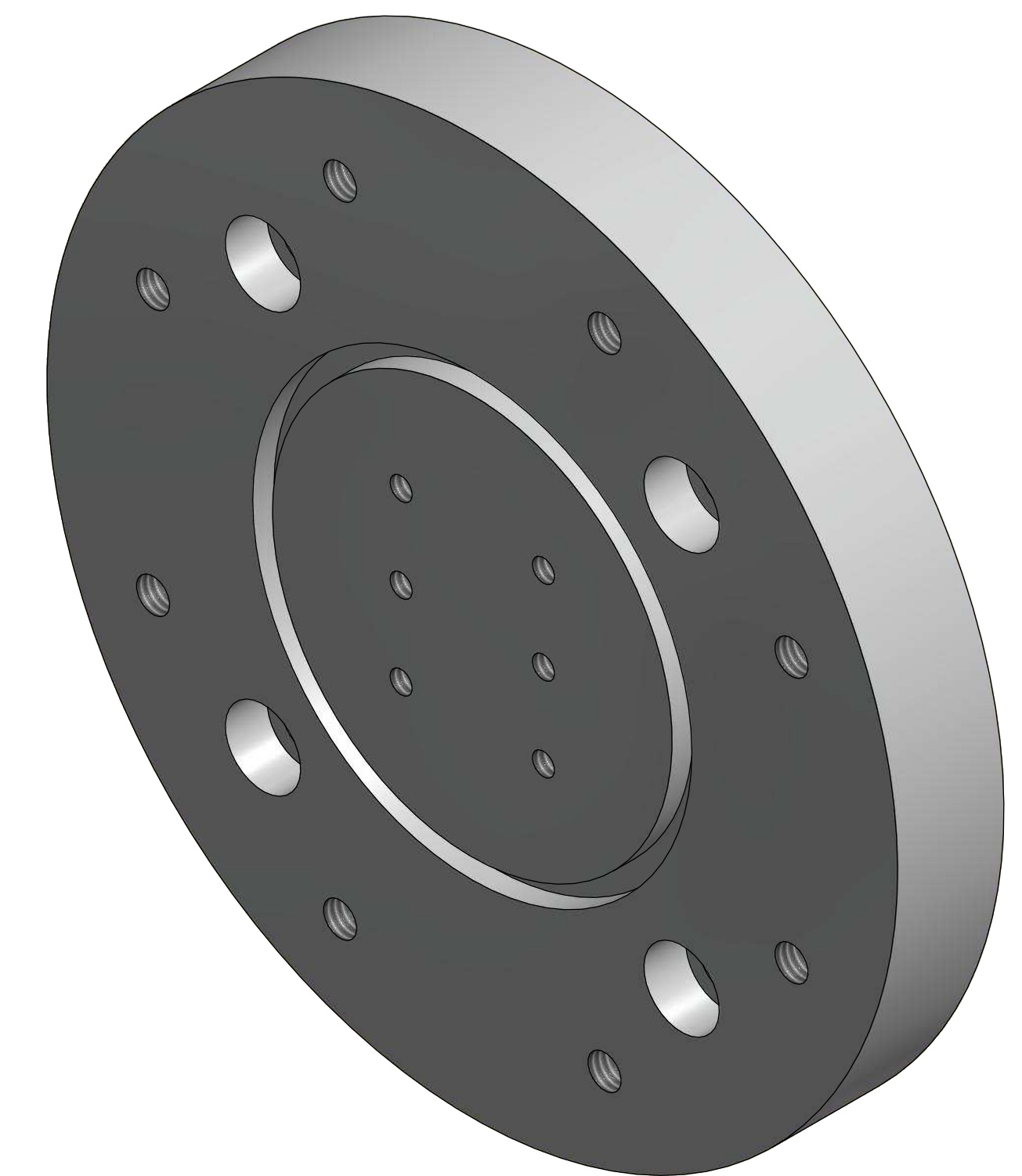
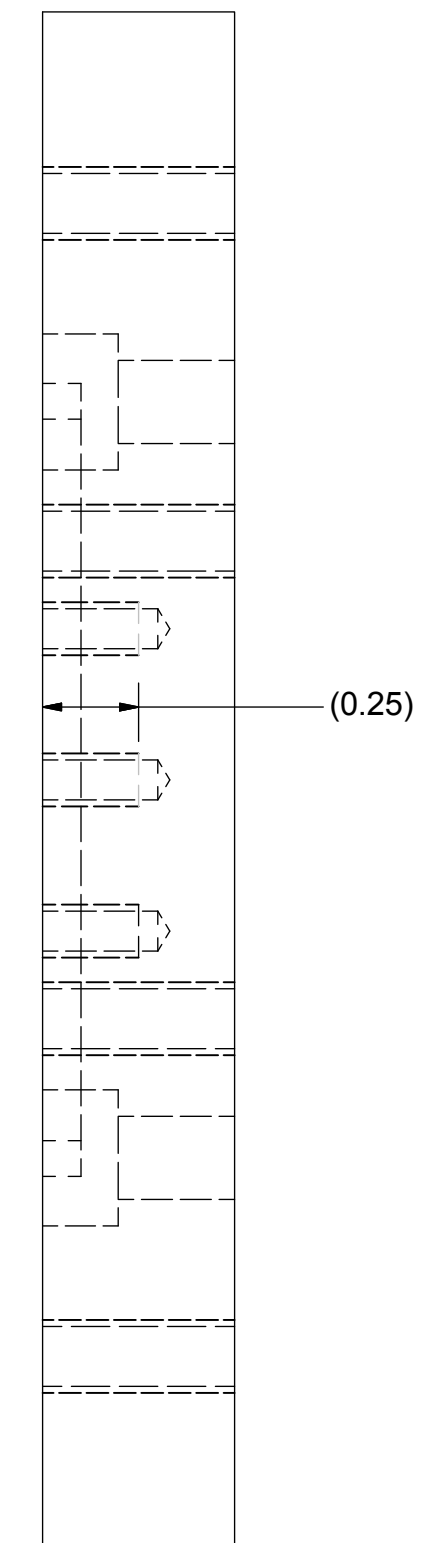
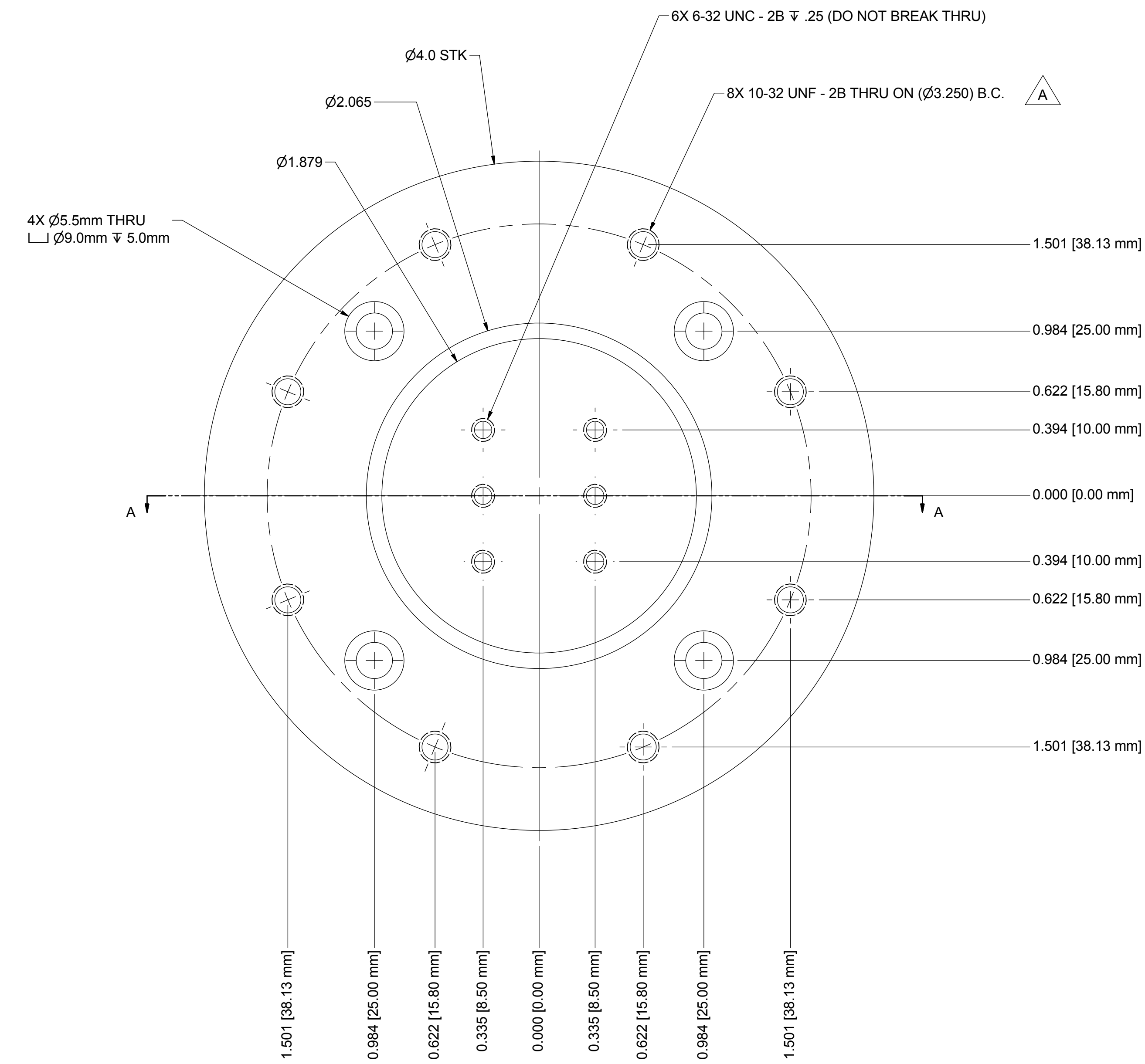

MIKE FISHER
 2-1576
 COST CODE: 60338-02-132
 QTY - 1
 TIGHT TOLERANCE ALUMINUM DISC PROVIDED AS FOLLOWS:

 0.500± 0.002 INCH LONG;
 PRECISION GROUND BOTH ENDS TO 0.010 INCH FLAT;
 4.000± 0.034 INCH DIAMETER.

	DRAWN: MVF	MATERIAL: Aluminum 6061	ESTIMATED MASS: N/A
	CHKD:	SIMILAR TO:	
ANSI Y14.5-2009 APPLIES EXCEPT AS NOTED: UNITS ARE: INCHES SURFACE FINISH: 125 ✓	APPRD:	APS 8-ID-INSTRUMENTATION	
3 PLACE DECIMAL ± 0.005 2 PLACE DECIMAL ± 0.015 1 PL. DEC. FRAC. ± 0.030, 1/32 ANGULAR TOLS. ± 0.5	SHEET: 1 OF 1	ADAPTOR	
ARGONNE NATIONAL LAB		SCALE 1:2	FIRST USED ON
		DATE 10/8/2014	8-ID-I-200
		DWG NO	8-ID-I-203
		SIZE	D
		REV	A

CHANGE LETTER	CHGD BY	CHKD BY	DATE	DESCRIPTION
A	MVF		10/9/14	10-32 WAS 10-24
				CHANGE

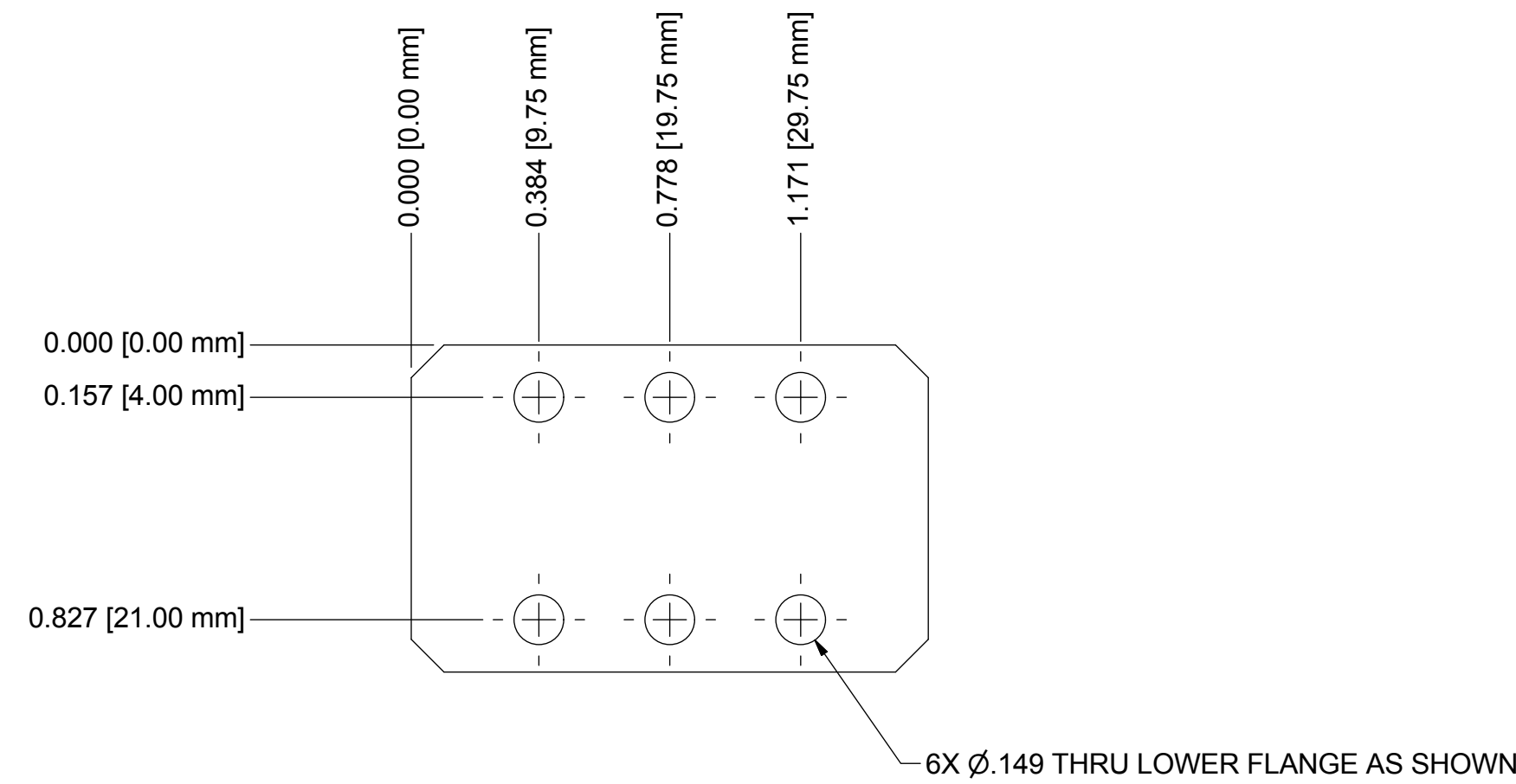
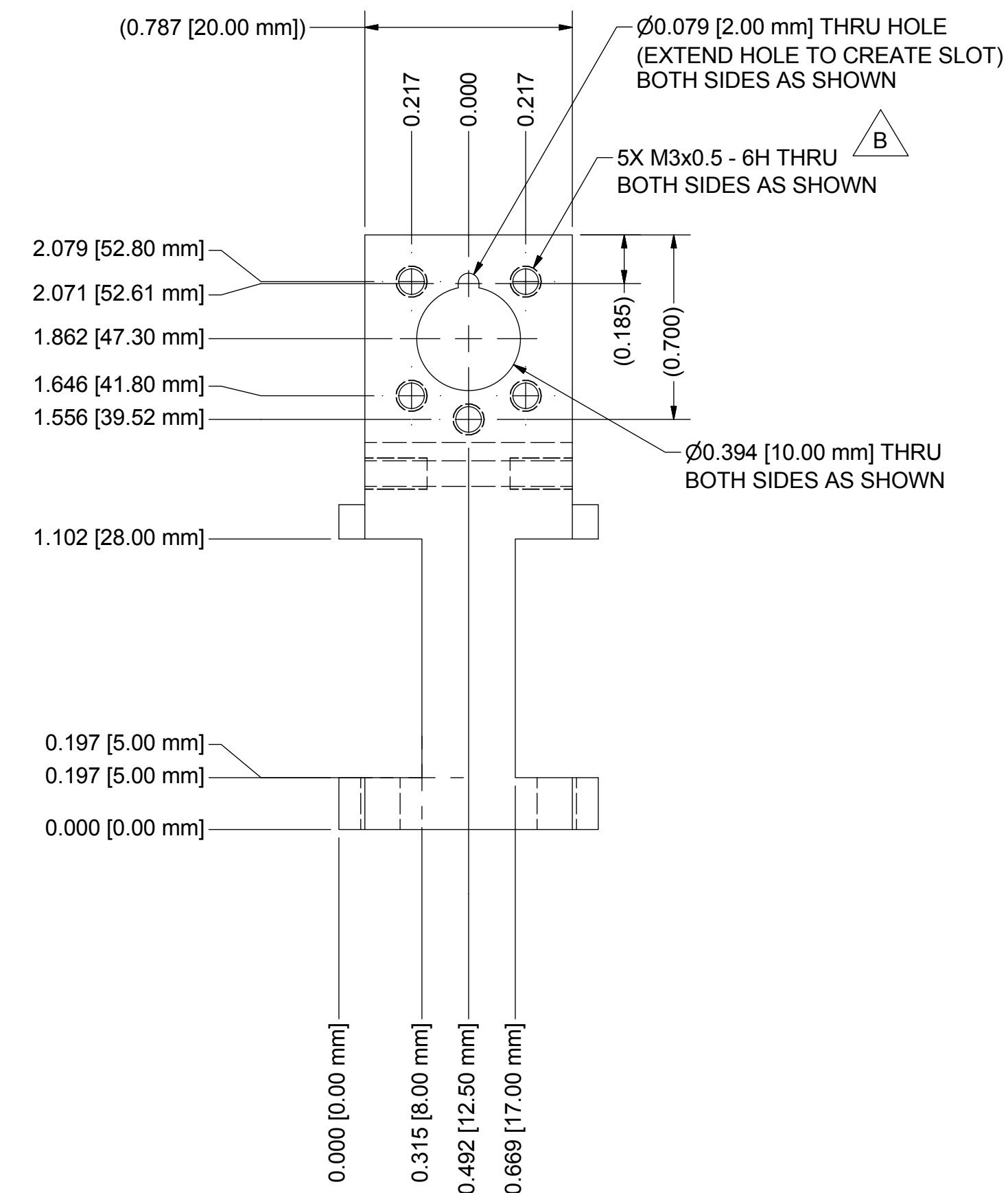
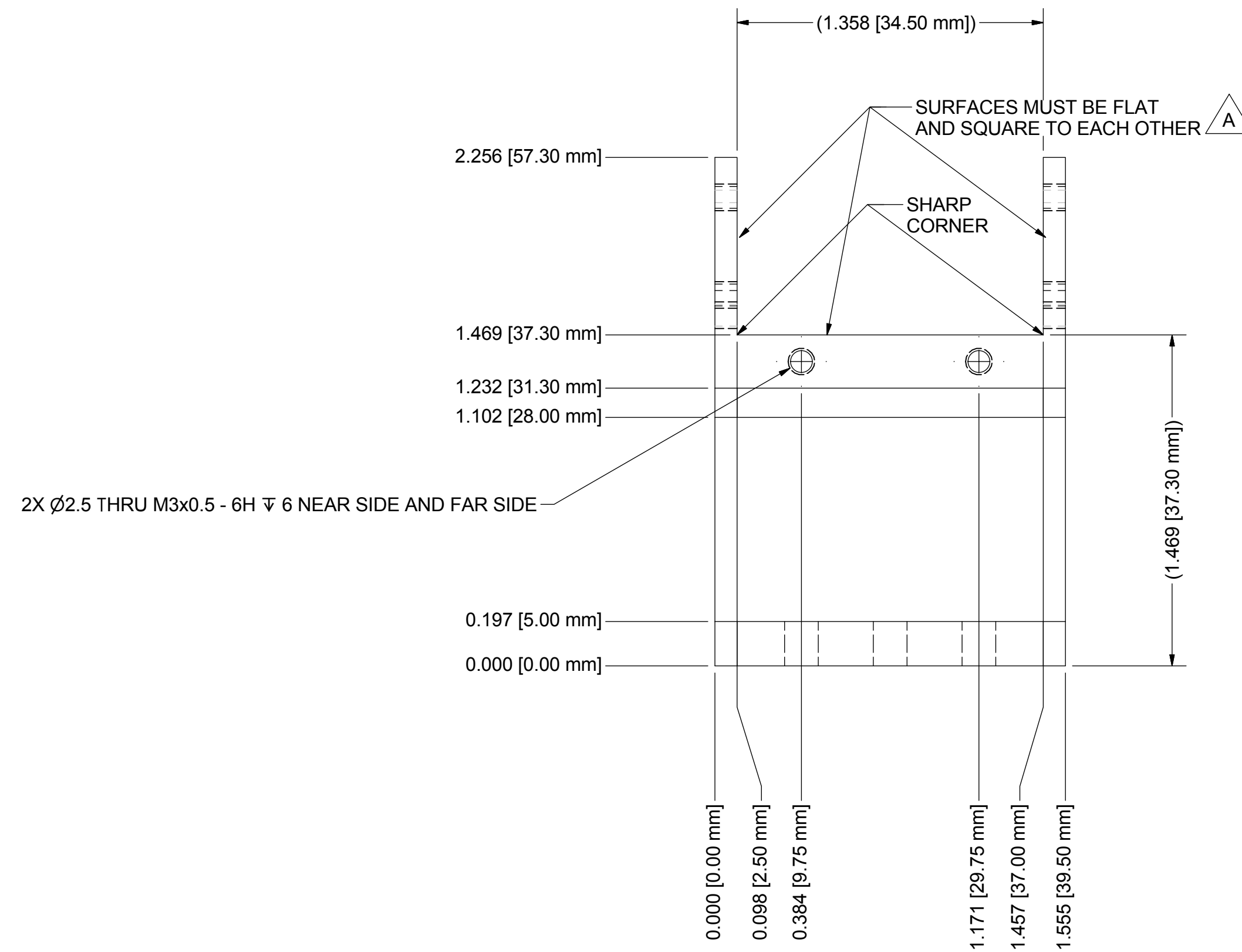
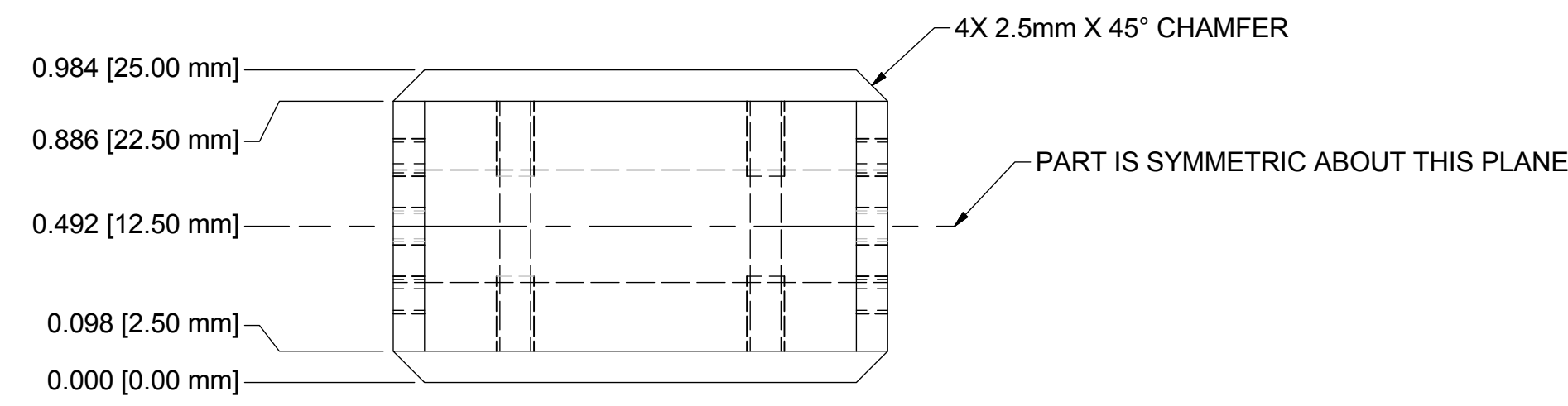
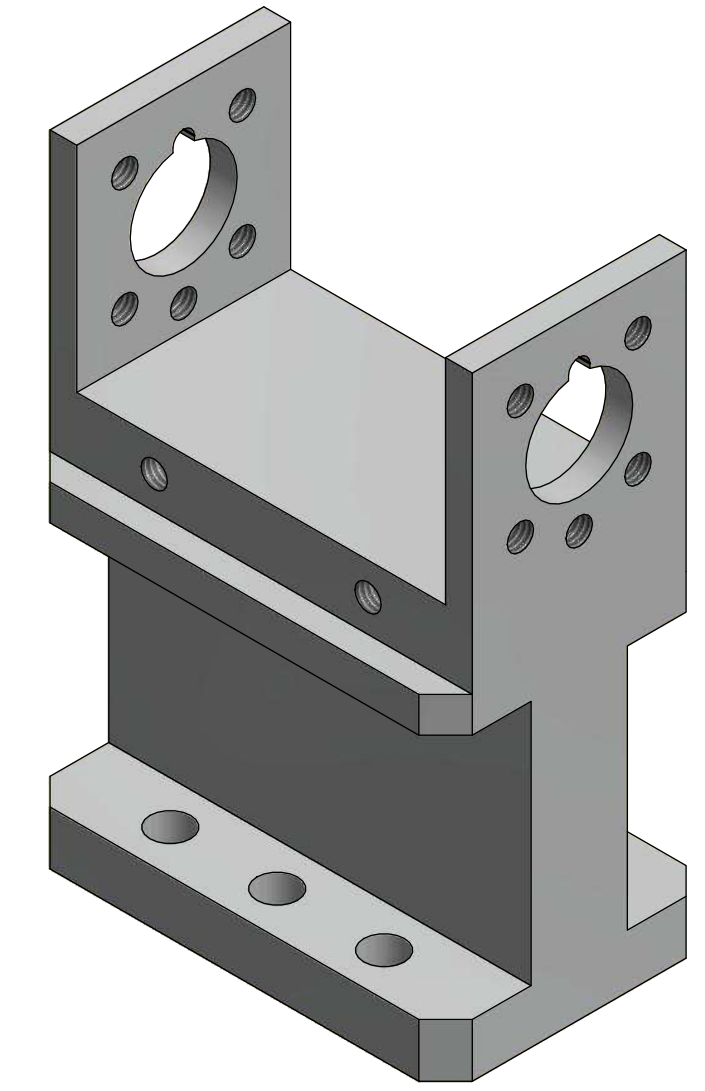
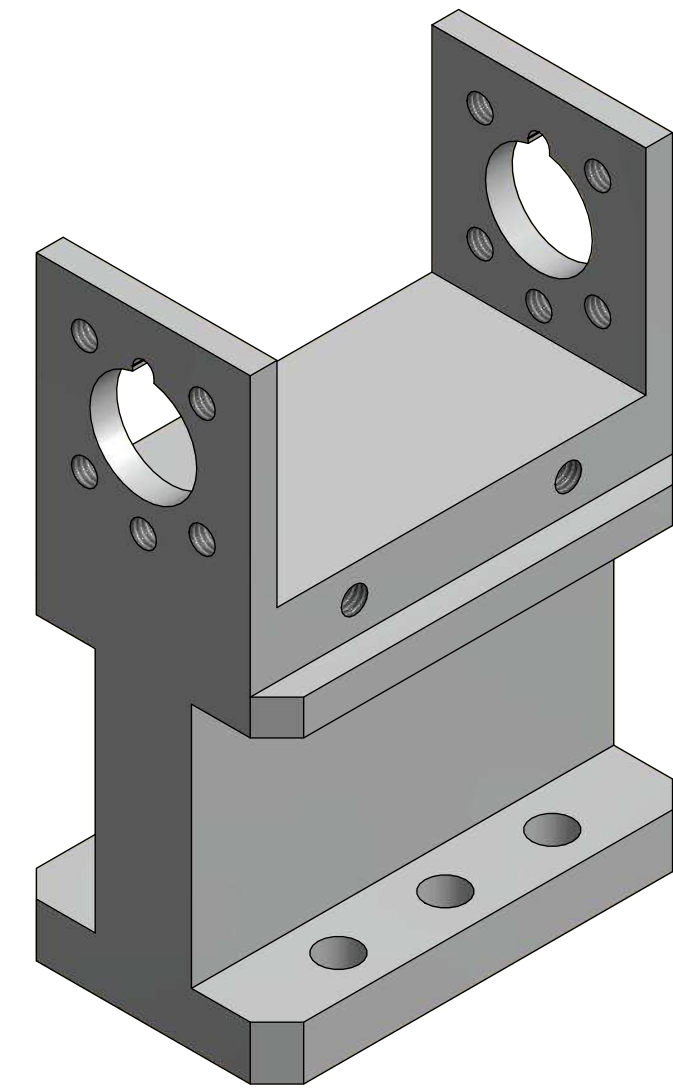

	DRAWN: MVF	MATERIAL: Aluminum 6061	ESTIMATED MASS: N/A
	CHKD:	SIMILAR TO:	
EXCEPT AS NOTED:	APPRD:	APS 8-ID-INSTRUMENTATION	
UNITS ARE: INCHES	SHEET:	LENSE HOLDER MAIN BODY	
SURFACE FINISH: 125 \checkmark	1 OF 1		
3 PLACE DECIMAL ± 0.005	ARGONNE ADVANCED PHOTON SOURCE NATIONAL LAB		
2 PLACE DECIMAL ± 0.015	SCALE 2:1	FIRST USED ON	DWG NO
1 PL DEC, FRAC. $\pm 0.030, 1/32$	DATE 3/28/2014	8-ID-I-204	8-ID-I-205
ANGULAR TOLS. ± 0.5			SIZE D
			REV B

B	MVF	1-29-15	ADDED 5TH HOLE TO BOLT PATTERN, ADDE 2mm THRU HOLE
A	MVF	10/9/14	ADDED NOTE TO 3 SURFACES
CHANGE LETTER	CHGD BY	CHKD BY	DATE
			CHANGE

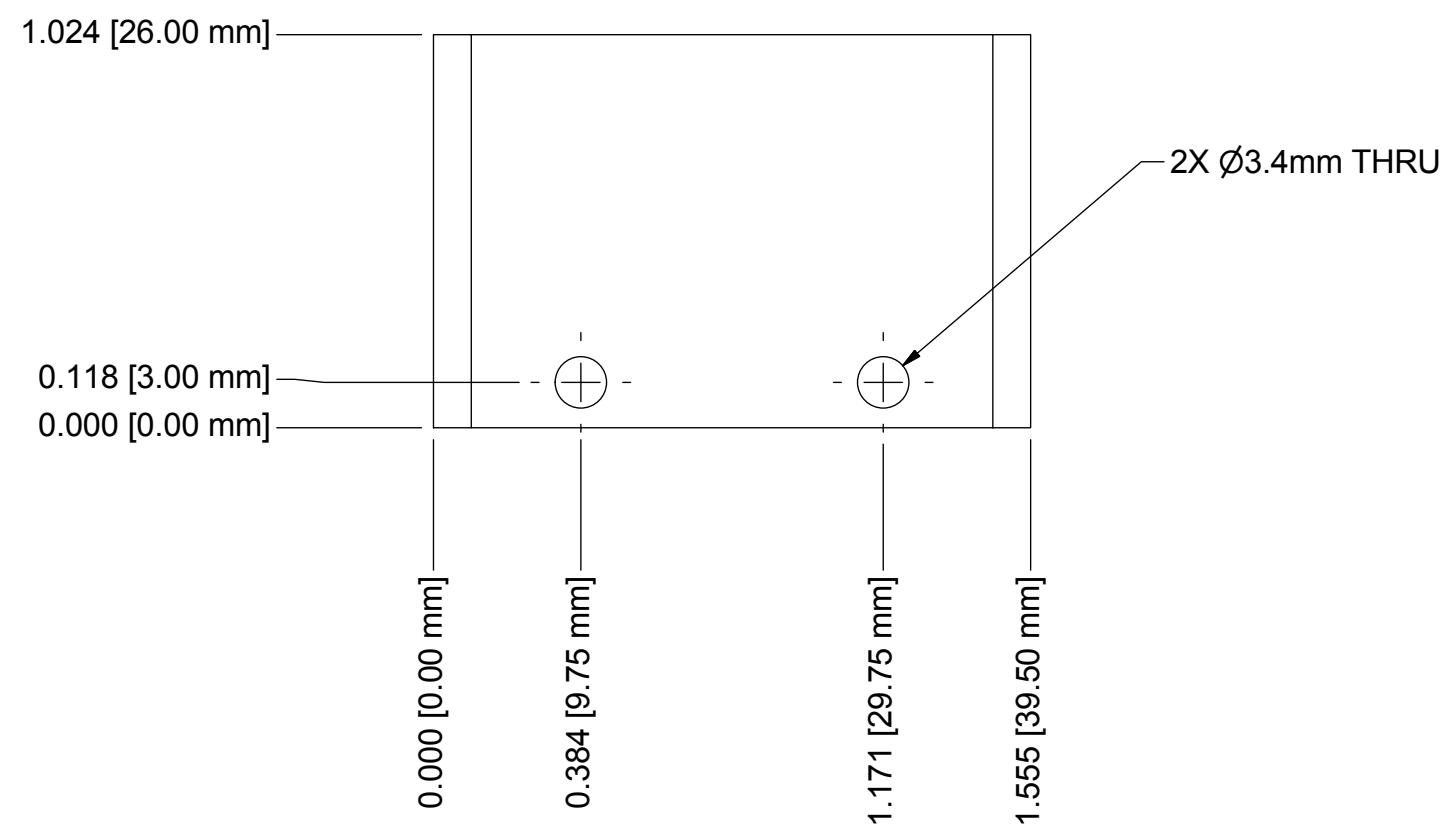
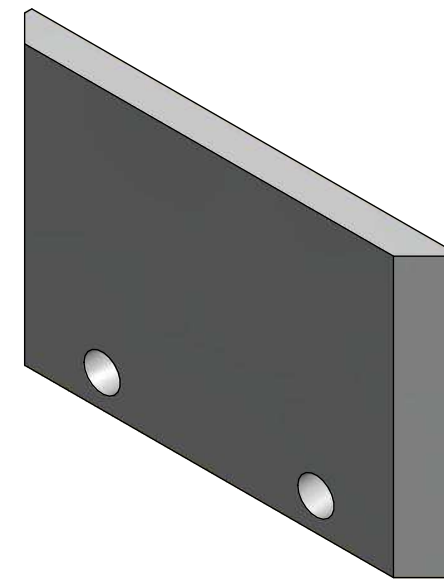
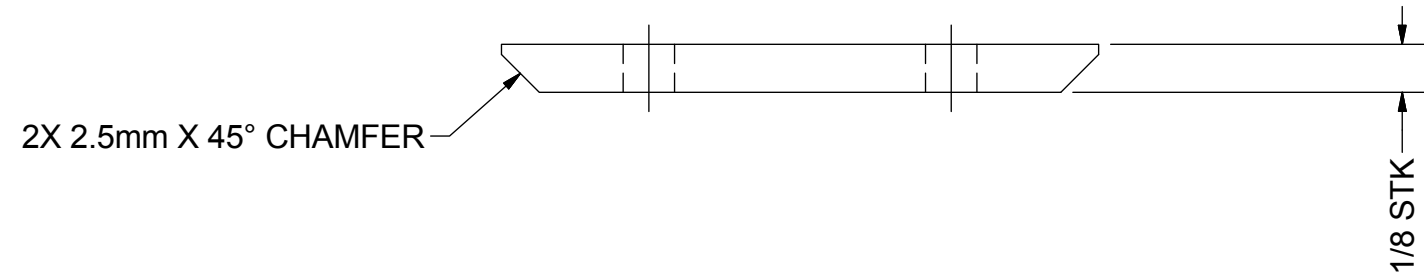

MIKE FISHER
 2-1576
 COST CODE: 60338-02-132
 QTY - 2
 1/8"X1.25"X6.0" ALUMINUM BAR PROVIDED

	DRAWN: MVF CHK'D: ANSI Y14.5-2009 APPLIES EXCEPT AS NOTED: UNITS ARE: INCHES SURFACE FINISH: 125 ✓ 3 PLACE DECIMAL ±0.005 2 PLACE DECIMAL ±0.015 1 PL DEC., FRAC. ±0.030, 1/32 ANGULAR TOL'S ±0.5	MATERIAL: Aluminum 6061 ESTIMATED MASS: N/A SIMILAR TO: APPR'D: SHEET: 1 OF 1 SIDE PLATE	ARGONNE ADVANCED PHOTON SOURCE <small>NATIONAL LAB</small>	
	DATE: 3/26/2014	FIRST USED ON: 8-ID-I-200	DWG NO: 8-ID-I-206	SIZE: C

CHANGE LETTER	CHGD BY	CHKD BY	DATE	CHANGE