

(M-)UTM

Mid-Range Travel Steel Linear Stages

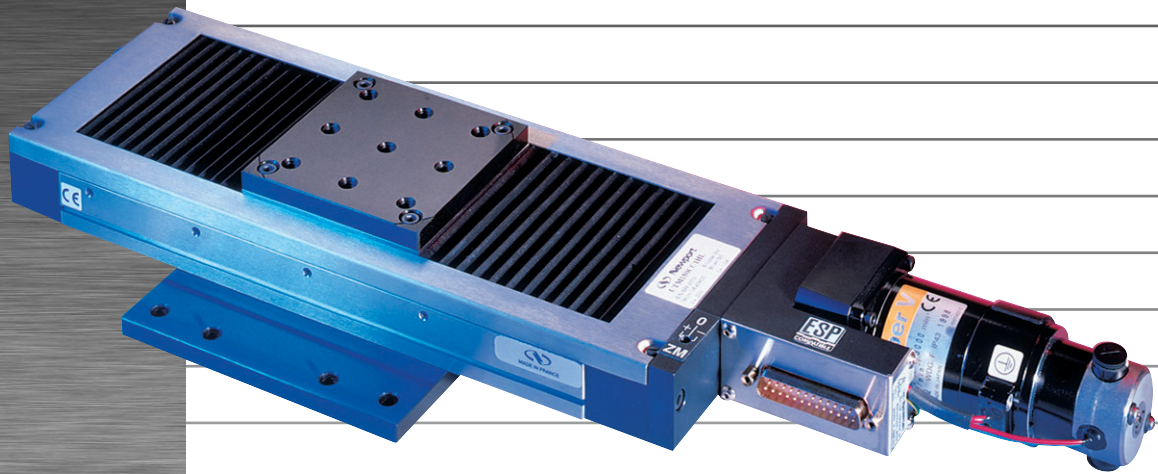

USER'S MANUAL

Warranty

Newport Corporation warrants this product to be free from defects in material and workmanship for a period of 1 year from the date of shipment. If found to be defective during the warranty period, the product will either be repaired or replaced at Newport's discretion.

To exercise this warranty, write or call your local Newport representative, or contact Newport headquarters in Irvine, California. You will be given prompt assistance and return instructions. Send the instrument, transportation prepaid, to the indicated service facility. Repairs will be made and the instrument returned, transportation prepaid. Repaired products are warranted for the balance of the original warranty period, or at least 90 days.

Limitation of Warranty

This warranty does not apply to defects resulting from modification or misuse of any product or part.

CAUTION

Warranty does not apply to damages resulting from:

- **Incorrect usage:**
 - **Load on the stage greater than maximum specified load.**
 - **Carriage speed higher than specified speed.**
 - **Improper grounding.**
 - **Connectors must be properly secured.**
 - **When the load on the stage represents an electrical risk, it must be connected to ground.**
 - **Excessive or improper cantilever loads.**
- **Modification of the stage or any part.**

This warranty is in lieu of all other warranties, expressed or implied, including any implied warranty of merchantability or fitness for a particular use. Newport Corporation shall not be liable for any indirect, special, or consequential damages.

No part of this manual may be reproduced or copied without the prior written approval of Newport Corporation.

This manual has been provided for information only and product specifications are subject to change without notice. Any changes will be reflected in future printings.

Table of Contents

Warrantyii
Table of Contents.....iii
Warningsv
Cautionsvi

1.0 — Introduction.....1

2.0 — Description2
2.1 Design Details3

3.0 — Characteristics.....3
3.1 Definitions3
3.2 Mechanical Specifications.....4
3.3 Load Specification Definitions4
3.4 Load Characteristics and Stiffness5
3.5 Stage Weights5

4.0 — Drive6
4.1 Stepper Drive Versions.....6
4.2 DC-Servo Drive Versions7
4.3 Manual Drive.....7

5.0 — Motor8
5.1 Stepper Motor Characteristics8
5.2 Command Signals for Stepper Motors.....8
5.3 DC-Motor Characteristics.....8
5.4 Command Signals for DC-Motors8
5.5 Sensor Position.....9
5.6 Feedback Signal Position.....9
5.7 Pinouts.....10

6.0 — Connection to Newport Controllers.....11
6.1 Warnings on controllers.....11
6.2 Connection.....12
6.3 Cables12

7.0 — Connection to Non-Newport Controllers.....14

8.0	— Mounting	15
8.1	Stage Mountings	15
8.2	Interfaces Disassembling	15
8.3	Mounting on Working Surface	17
8.4	Assembling by the Carriage.....	18
8.5	Disassembling.....	18
8.6	Interface Plates Mounting	18
8.7	Assembly Pattern	18

9.0	— Dimensions	19
------------	---------------------------	----

10.0	— Accessories: EQ100 Brackets	20
-------------	--	----

11.0	— Maintenance	21
11.1	Maintenance.....	21
11.2	Repairing	21
11.3	Calibration.....	21

Service Form	22
--------------------	----

We declare that the accompanying product, identified with the “CE” mark, meets all relevant requirements of Directives:

- 73/23/EEC, for Low Voltage Compatibility.
- 89/336/EEC for Electromagnetic Compatibility.

Generic standard:

Emission: NF EN61326-1, for measurement, lab and control equipment.

Immunity: NF EN61326-1, for measurement, lab and control equipment.

Safety: EIC 1010-1, safety standards for measurement, lab and control equipment.

Newport Corporation shall not be liable for damages when using the product:

- Modification of the product.
- Using modified connector, or modified or not supplied cables.
- Connecting this product to non-CE equipment.

Warnings

WARNING

The translation of objects of all types carries potential risks for operators. Ensure the protection of operators by prohibiting access to the dangerous area and by informing the personnel of the potential risks involved.

WARNING

Do not use this stage when its motor is emitting smoke or is unusually hot to the touch or is emitting any unusual odor or noise or is in any other abnormal state.

Stop using the stage immediately, switch off the motor power and then disconnect the electronics power supply.

After checking that smoke is no longer being emitted contact your Newport service facility and request repairs. Never attempt to repair the stage yourself as this can be dangerous.

WARNING

Make sure that this stage is not exposed to moisture and that liquid does not get into the stage.

Nevertheless, if any liquid has entered the stage, switch off the motor power and then disconnect the electronics from power supply.

Contact your Newport service facility and request repairs.

WARNING

Do not insert or drop objects into this stage, this may cause an electric shock, or lock the drive.

Do not use this stage if any foreign objects have entered the stage. Switch off the motor power and then disconnect the electronics power supply.

Contact your Newport service facility for repairs.

WARNING

Do not place this stage in unstable locations such as on a wobbly table or sloping surface, where it may fall or tip over and cause injury.

If this stage has been dropped or the case has been damaged, switch off the motor power and then disconnect the electronics power supply.

Contact your Newport service facility and request repairs.

WARNING

Do not attempt to modify this stage; this may cause an electric shock or downgrade its performance.

WARNING

Do not exceed the usable depth indicated on the mounting holes (see section "Dimensions"). Longer screws can damage the mechanics or cause a short-circuit.

Cautions

CAUTION

Do not place this stage in a hostile environment such as X-Rays, hard UV,... or in a vacuum environment less than 10^{-2} Torr.

CAUTION

Do not place this stage in a location affected by dust, oil fumes or steam. This may cause an electric shock.

CAUTION

Do not leave this stage in places subject to extremely high temperatures or low temperatures. This may cause an electric shock.

- Operating temperature: +10 to +35 °C.
 - Storage temperature: -10 to +40 °C (in its original packaging).
-

CAUTION

Do not move this stage if its motor power is on.

Make sure that the cable to the electronics is disconnected before moving the stage. Failure to do so may damage the cable and cause an electrical shock.

CAUTION

Be careful that the stage is not bumped when it is being carried. This may cause it to malfunction.

CAUTION

When handling this stage, always unplug the equipment from the power source for safety.

CAUTION

When the carriage is in end-of-run position, it is strongly recommended not to go beyond this point by using the manual knob as this may damage the stage mechanism.

CAUTION

Contact your Newport service facility to request cleaning and specification control every year.

Mid-Range Travel Steel Linear Stages

(M-)UTM

1.0 Introduction

This manual provides operating instructions for the stage that you have purchased in the (M-)UTM Series:

- (M-)UTMPP1HL
- (M-)UTMPP.1
- (M-)UTMPE1
- (M-)UTMPE.1
- (M-)UTMPE1V6 ⁽¹⁾
- (M-)UTMPE.1V6 ⁽¹⁾
- (M-)UTMCC.1
- (M-)UTMCC1HL
- (M-)UTMCC1DD
- (M-)UTMCC.1DD
- (M-)UTMMS1
- (M-)UTMMS.1

¹⁾ REMARK

Vacuum compatible stages to 10^{-6} Torr. In this case, max. speed and load capacity have to be divided by two.

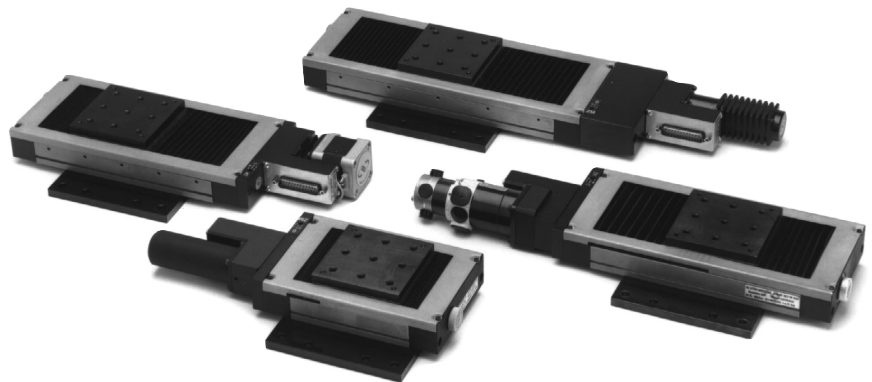

(M-)UTM Series linear stages.

RECOMMENDATION

We recommend you read carefully the chapter “Connection to electronics” before using the (M-)UTM stage.

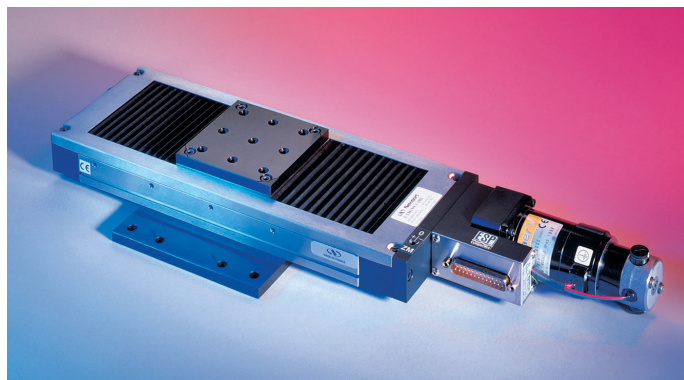

2.0 Description

The (M-)UTM Series translation stages feature steel construction with pre-loaded ball bearing slides and a backlash-compensated leadscrew for superior performance over medium travel ranges.

These motorized stages are equipped with mechanical limit switches to prevent damage to the bearings from accidental overtravel. A center home position allows the stage to be returned to a reference position in the middle of the stage's travel at any time.

The home position (Mechanical Zero) may also be set to either end of the stage's travel via an external switch on the stage body:

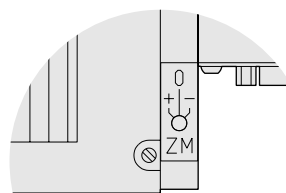

- + : Origin, side opposite motor.
- 0 : Origin at stage center.
- : Origin on motor side.

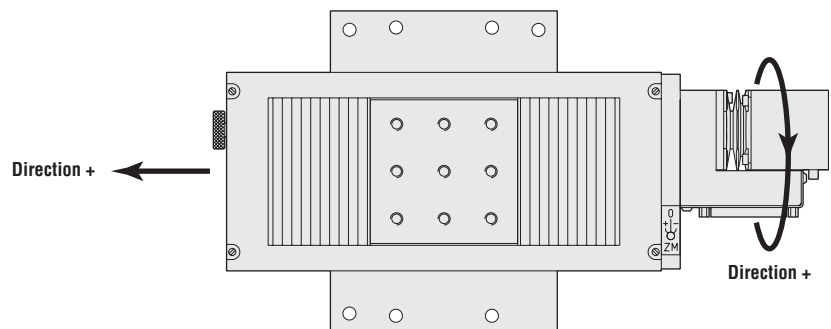

Position measuring is performed with a 2000 pts/rev. encoder, integral with the motor shaft and a 2 mm pitch backlash compensated leadscrew.

All (M-)UTM Series stages are equipped with a knurled knob for a manual control.

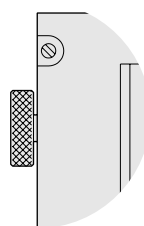

The modular design of (M-)UTM stages brings you the flexibility to choose the drive configuration that best matches your specific application requirements: high-resolution 0.1 μm version or higher speed 1 μm version, manual, DC-motor or stepper motor driven versions, with mini-step or full-step drive options.

For optimal performance, we recommend the use of our ESP or MM series motion controllers.

The (M-)UTM Series stages are supplied with a 3-meter cable for connection to our motion controllers.

2.1 Design Details

Base Material	Stainless Steel
Bearings	Linear ball bearings
Drive Mechanism	Backlash-compensated leadscrew
Drive Screw Pitch (mm)	2
Reduction Gear	10:1 on all versions with 0.1 µm resolution ⁽¹⁾
Feedback	2000 pts/rev. rotary encoder with index pulse
Limit Switches	Mechanical
Origin	Centered, can be set to left or right travel limit via external switch
Protection	Bellows
Vacuum Compatibility	Vacuum compatible versions are available up to 10 ⁻⁶ Torr using full-step motor (PE1 and PE.1)

¹⁾ Additional motor mounted gear on some drive option.

3.0 Characteristics

3.1 Definitions

Specifications of our products are established in reference to ISO 230 standard part II “Determination of the position, precision and repeatability of the machine tools with CNC”.

This standard gives the definition of position uncertainty which depends on the 3 following quantities:

(Absolute) Accuracy

Difference between ideal position and real position.

On-Axis Accuracy

Difference between ideal position and real position after the compensation of linear error sources.

Linear errors include: cosine errors, inaccuracy of screw or linear scale pitch, angular deviation at the measuring point (Abbe error) and thermal expansion effect. All Newport motion electronics can compensate for linear accuracy errors by step encoder correction.

The relation between absolute accuracy and on-axis accuracy is as follow:

$$\text{Absolute Accuracy} = \text{On-Axis Accuracy} + \text{Slope} \times \text{Travel}$$

Repeatability

Ability of a system to achieve a commanded position over many attempts.

Reversal Value (Hysteresis)

Difference between actual position values obtained for a given target position when approached from opposite directions.

Minimum Incremental Motion (Sensitivity)

Minimum motion that a stage can achieve. Our stages and our kinematic chain are conceived in such a way that sensitivity is better than the resolution of the encoder.

Resolution

The smallest motion an encoder fixed to the stage can measure.

Yaw, Pitch

Rotation of carriage around the Z axis (Yaw) or Y axis (Pitch), when it moves.

The testing of on-axis accuracy, repeatability, and reversal error are made systematically with our test equipment in an air-conditioned room (20 °C ±1 °C).

Each stage is tested with a laser interferometer.

A linear cycle with 21 measures on the travel and 4 cycles in each direction gives a total of 164 points.

3.2 Mechanical Specifications

Travel Range	(mm)	25; 50; 100 and 150
Unidirectional Repeatability	(µm)	1.5
Reversal Value (Hysteresis)	(µm)	3.0 (PP1, PE1, CC1HL, CC1DD) 3.5 (PP.1, PE.1, CC.1, CC.1DD)
On-Axis Accuracy ⁽¹⁾	(µm)	5.0
αy Pitch ⁽¹⁾	(µrad)	110
αz Yaw ⁽¹⁾	(µrad)	70

¹⁾ For a travel of 100 mm.

3.3 Load Specification Definitions**Normal Load Capacity (Cz)**

Maximum load a stage can move while maintaining specifications.

This value is given with speed and acceleration specified for each stage, and with a load perpendicular to bearings.

Axial Load Capacity (±Cx)

Maximum load along the direction of the drive train.

Off-Centered Load (Q)

Maximum cantilever-load a stage can move: $Q \leq Cz / (1 + D/50)$

D: Cantilever distance.

3.4 Load Characteristics and Stiffness

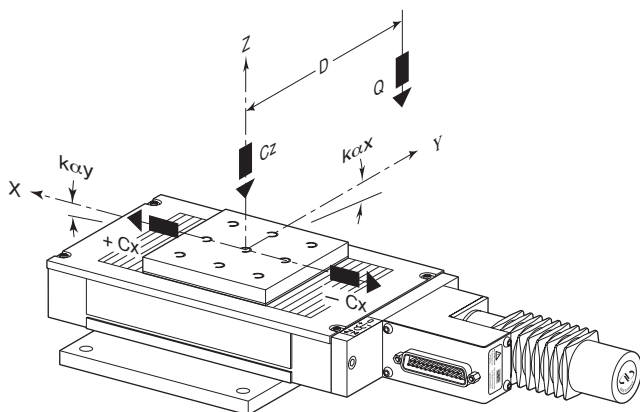

Cz	(N)	200
-Cx	(N)	10
+Cx	(N)	50
kαx	(μrad/N.m)	10
kαy	(μrad/N.m)	15

- Q: Off-center load, $Q \leq Cz / (1 + D/50)$
- D: Cantilever distance in mm
- Cz: Normal center load capacity on bearings
- +Cx: Direct load capacity on X axis
- Cx: Inverse load capacity on X axis
- kαx: Angular stiffness (Roll)
- kαy: Angular stiffness (Pitch)

3.5 Stage Weights

Weights indicated into the below table are average values for stages with a typical drive unit installed.

(M-)UTM25	[lb (kg)]	6.6 (3)
(M-)UTM50	[lb (kg)]	7.1 (3.2)
(M-)UTM100	[lb (kg)]	7.7 (3.5)
(M-)UTM150	[lb (kg)]	8.4 (3.8)

The weight variation between drive units is not very significant.

4.0 Drive

4.1 Stepper Drive Versions

Stepper-motor-driven stages are offered in four variants:

- Two mini-step drive versions with resolutions of 1 μm (PP1HL) and 0.1 μm (PP.1). These combine high speed positioning and smooth displacement from 1/10-stepper encoder count driving mode. For ultrasmooth low-speed positioning, microstepping up to 250x is possible using ESP Series Controllers.
- Two full-step versions with resolutions of 1 μm (PE1) and 0.1 μm (PE.1). These are primarily designed for applications requiring the position to be maintained within the stage's resolution when power is switched off, such as operation in vacuum.

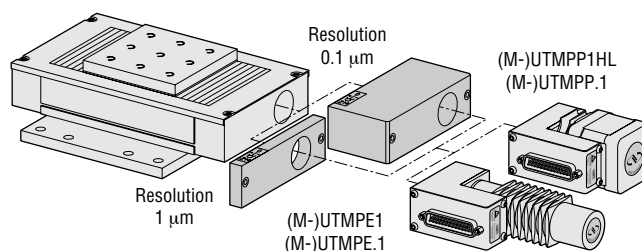

Mini-Step Drive

Is used for stepper motors, when 1 pulse emitted by electronic corresponds to theoretical physical motion of a fraction of a full step of the motor.

For these stages a mini-step equals 1/10 of a full step.

Full-Step Drive

Is used for stepper motors, when 1 pulse emitted by electronic corresponds to theoretical physical motion of 1 full step of the motor.

Stepper Motor Performance Specifications

	Resolution (μm)	Speed (mm/sec)	Motor
(M-)UTMPP1HL	1	20	UE41PP
(M-)UTMPP.1	0.1	2	
(M-)UTMPE1	1	2	UE31PP
(M-)UTMPE.1	0.1	0.2	

4.2 DC-Servo Drive Versions

Four DC-motor-driven configurations are available:

- Two high-power DC-Servo versions with resolutions of 1 μm (CC1HL) and 0.1 μm (CC.1). The CC1HL features a built-in tachometer to provide superior speed stability.
- Two low-power versions with resolutions of 1 μm (CC1DD) and 0.1 μm (CC.1DD). These stages offer a cost-effective performance alternative for those who have precision positioning needs with budget limitations.

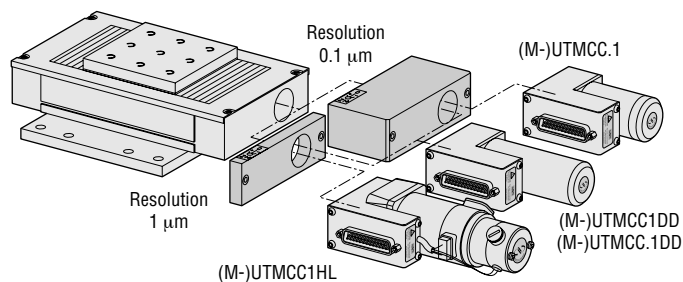

DC-Motor Performance Specifications

	Resolution (μm)	Speed (mm/sec)	Motor
(M-)UTMCC.1	0.1	2	UE33CC
(M-)UTMCC1HL	1	20	UE404CC
(M-)UTMCC1DD	1	2.5	UE31CC
(M-)UTMCC.1DD	0.1	0.25	

4.3 Manual Drive

Two manual drive versions are available with resolutions of 1 μm (MS1) and 0.1 μm (MS.1). In addition to the vernier scale on the manual drive, position may be determined using the output from the incremental shaft encoder. A connector for the CV1000 encoder display is provided.

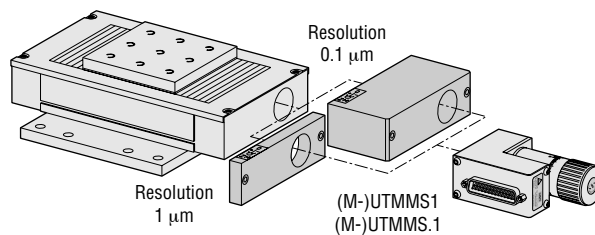

Manual Performance Specifications

	Resolution (μm)	Travel per Revolution (mm/rev.)
(M-)UTMMS1	1	2
(M-)UTMMS.1	0.1	0.2

5.0 Motor

5.1 Stepper Motor Characteristics

Motor	Angle by Step (°)	Current (A)	Resistance (Ω)	Inductance (mH)	Newport Utilization
UE31PP	3.6	0.56	7.6	8.4	Full-Step
UE41PP	1.8	1.2	3	4.3	Full-Step or Mini-Step

5.2 Command Signals for Stepper Motors

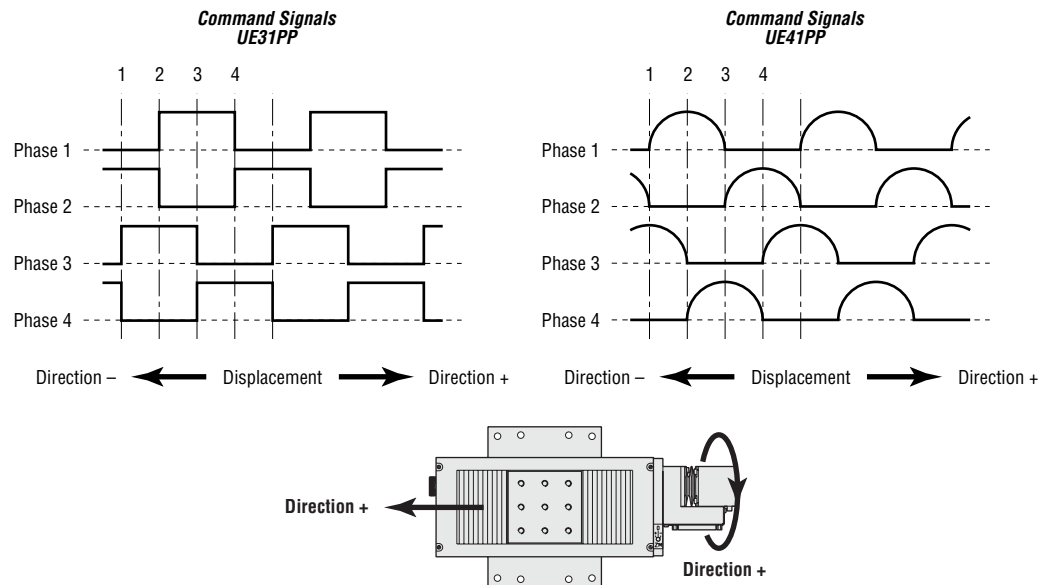

5.3 DC-Motor Characteristics

Motor	Mechanical Power (W)	Nominal Voltage (V)	Armature Resistance (Ω)	Tachometer (V/Krpm)
UE31CC	2.53	24	57	-
UE33CC	23	36	14	-
UE404CC	40	75	18.6	3 (±10%)

5.4 Command Signals for DC-Motors

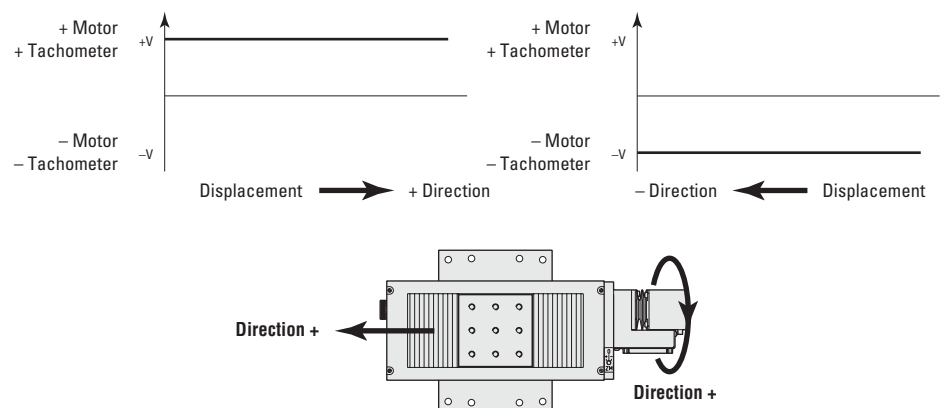

In the above drawings, + Motor signal is referred to - Motor signal, + Tacho Generator is referred to - Tacho Generator signal.

- ① When the stage moves in + Direction, the + Motor voltage is higher than - Motor voltage, and + Tacho Generator voltage is higher than - Tacho Generator voltage.
- ② When the stage moves in - Direction, the + Motor voltage is lower than - Motor voltage, and + Tacho Generator voltage is lower than - Tacho Generator voltage.

5.5 Sensor Position

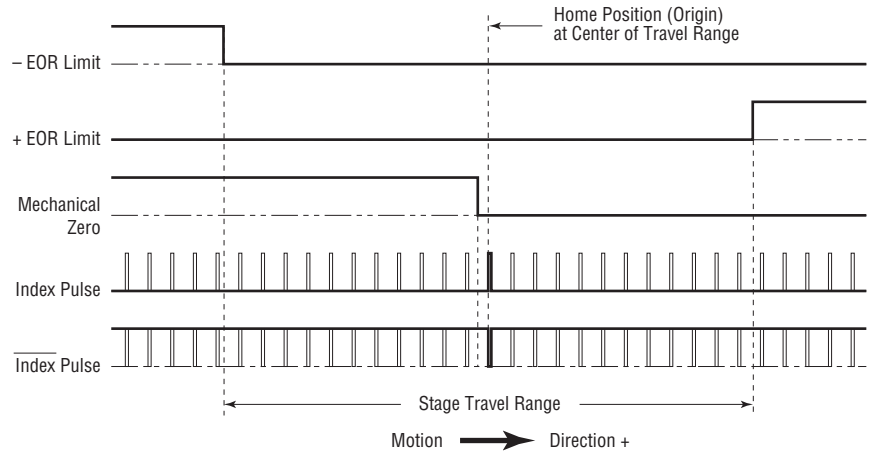

End-of-Run and Mechanical Zero are TTL type: 5 V ±5%, 2 mA max.

Use of the Index Pulse provides a repeatable Home Position at ±1 step.

CAUTION

“End-of-Run” and “Mechanical Zero” are active signals and should not be connected to any other source. Use appropriate TTL type receivers.

5.6 Feedback Signal Position

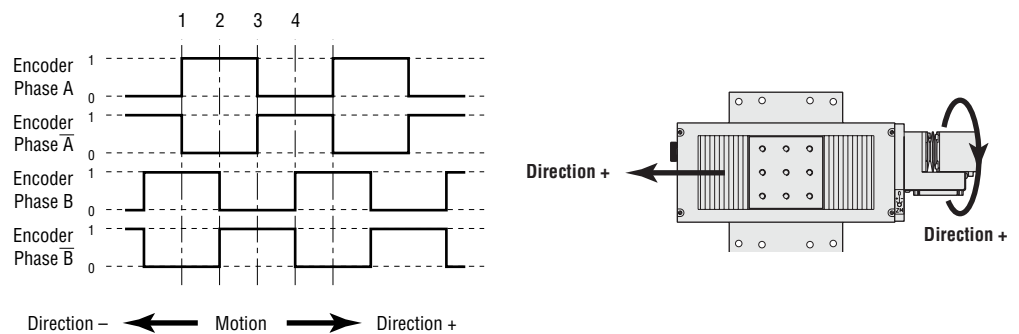

The incremental sensor operates following the photoelectric measurement principle, with a disk including slides. When the sensor shaft turns, the sensor generates square signals in quadrature, sent to pins #19, #20, #23 and #24 of the 25-pin Sub-D connector.

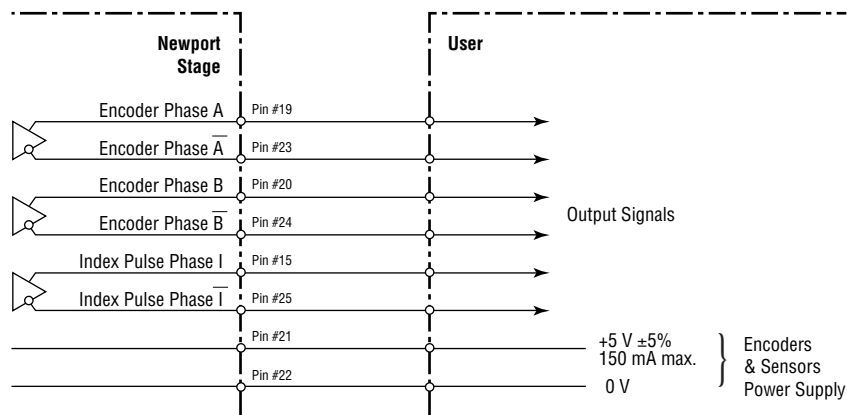

5.7 Pinouts

The 25-pin Sub-D connection for the (M-)UTM stages is given in the following table:

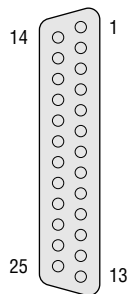

UE31PP: (M-)UTMPE1 & PE.1 UE41PP: (M-)UTMPP1HL & PP.1	UE31CC: (M-)UTMCC1DD & CC.1DD UE33CC: (M-)UTMCC.1	UE404CC: (M-)UTMCC1HL	Manual: (M-)UTMMS1 & MS.1
1 Phase 1	1 N.C.	1 + Tachometer	1 N.C.
2 Phase 1	2 N.C.	2 + Tachometer	2 N.C.
3 Phase 2	3 N.C.	3 - Tachometer	3 N.C.
4 Phase 2	4 N.C.	4 - Tachometer	4 N.C.
5 Phase 3	5 + Motor	5 + Motor	5 N.C.
6 Phase 3	6 + Motor	6 + Motor	6 N.C.
7 Phase 4	7 - Motor	7 - Motor	7 N.C.
8 Phase 4	8 - Motor	8 - Motor	8 N.C.
9 Common Phase 3-4	9 N.C.	9 N.C.	9 N.C.
10 N.C.	10 N.C.	10 N.C.	10 N.C.
11 Common Phase 1-2	11 N.C.	11 N.C.	11 N.C.
12 N.C.	12 N.C.	12 N.C.	12 N.C.
13 Mechanical Zero	13 Mechanical Zero	13 Mechanical Zero	13 Mechanical Zero
14 Shield Ground	14 Shield Ground	14 Shield Ground	14 Shield Ground
15 Index Pulse I	15 Index Pulse I	15 Index Pulse I	15 Index Pulse I
16 0 V logic	16 0 V logic	16 0 V logic	16 0 V logic
17 + End-of-Run	17 + End-of-Run	17 + End-of-Run	17 + End-of-Run
18 - End-of-Run	18 - End-of-Run	18 - End-of-Run	18 - End-of-Run
19 Encoder Phase A	19 Encoder Phase A	19 Encoder Phase A	19 Encoder Phase A
20 Encoder Phase B	20 Encoder Phase B	20 Encoder Phase B	20 Encoder Phase B
21 Encoder Power: +5 V	21 Encoder Power: +5 V	21 Encoder Power: +5 V	21 Encoder Power: +5 V
22 0 V Encoder	22 0 V Encoder	22 0 V Encoder	22 0 V Encoder
23 Encoder Phase /A	23 Encoder Phase /A	23 Encoder Phase /A	23 Encoder Phase /A
24 Encoder Phase /B	24 Encoder Phase /B	24 Encoder Phase /B	24 Encoder Phase /B
25 Index Pulse /I	25 Index Pulse /I	25 Index Pulse /I	25 Index Pulse /I

6.0 Connection to Newport Controllers

6.1 Warnings on controllers

Controllers are intended for use by qualified personnel who recognize shock hazards and are familiar with safety precautions required to avoid possible injury. Read the controller user's manual carefully before operating the instrument and pay attention to all written warnings and cautions.

WARNING

Disconnect the power plug under the following circumstances:

- If the power cord or any attached cables are frayed or damaged in any way.
- If the power plug is damaged in any way.
- If the unit is exposed to rain, excessive moisture, or liquids are spilled on the unit.
- If the unit has been dropped or the case is damaged.
- If you suspect service or repair is required.
- Whenever you clean the electronics unit.

CAUTION

To protect the unit from damage, be sure to:

- Keep all air vents free of dirt and dust.
- Keep all liquids away from the unit.
- Do not expose the unit to excessive moisture (>85% humidity).
- Read this manual before using the unit for the first time.

WARNING

All attachment plug receptacles in the vicinity of this unit are to be of the grounding type and properly polarized.

Contact your electrician to check your receptacles.

WARNING

This product is equipped with a 3-wire grounding type plug.

Any interruption of the grounding connection can create an electric shock hazard.

If you are unable to insert the plug into your wall plug receptacle, contact your electrician to perform the necessary alterations to ensure that the green (green-yellow) wire is attached to earth ground.

WARNING

This product operates with voltages that can be lethal.

Pushing objects of any kind into cabinet slots or holes, or spilling any liquid on the product, may touch hazardous voltage points or short out parts.

6.2 Connection

On each stage is represented a label which indicates its name, its serial number and the motor it is equipped with (ex.: UE31PP).

M-UTM100PE.1	S/N#
ENCODER:5V	MOTOR:UE31PP
Stepper Motor	U=30VDC I=1A

WARNING

Always turn the controller's power OFF before connecting to a stage.

Stages may be connected to the rear panel motor connectors labeled "Motor..." any time prior to power-up with the supplied cable assemblies.

WARNING

With MM series controllers, damage to stage may occur if the stage is not the same type as shown on driver label located near the stage interface connector.

Check that the option number specified on this label correspond to the number indicated in the driver module options table for your stage.

WARNING

Vacuum compatible stages have to be configured if running with an ESP series controller.

6.3 Cables

All our (M-)UTM stages are delivered equipped with a 3-meter cable with 25-pin Sub-D connectors so they can be directly connected to our controllers/drivers of MM or ESP series.

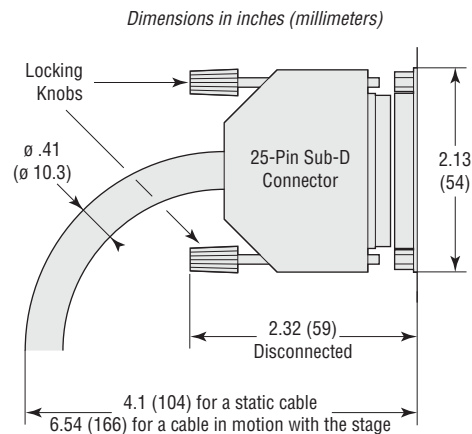

WARNING

This cable is shielded correctly. For a correct operation, make sure to lock connectors (ground continuity provided by the cable).

For applications where the standard 3-meter cable (MMCABLE-3) included with your stage is not adequate, Newport offers longer length cables designed to ensure the integrity of your positioning application.



These cables are specially shielded and terminated with Newport’s standard 25-pin sub-D connectors. They are available in 5-m (MMCABLE-5), 7-m (MMCABLE-7) or 10-m (MMCABLE-10) lengths.

WARNING

Keep the motor cables at a safe distance from other electrical cables in your environment to avoid potential cross talk.

For cable lengths in excess of 3 meters, we recommend the MMCABLE-REG to ensure a high quality, regulated 5 V supply to the stages.

Dimensions in inches (millimeters)

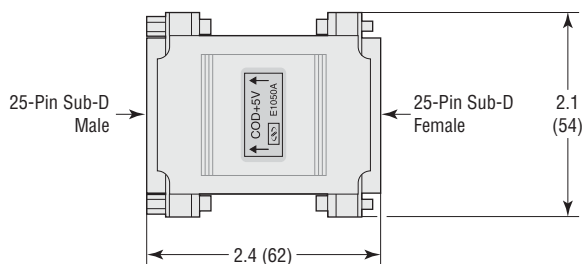

This regulator is available as an option. Please note that for best efficiency, this regulator should be attached to the stage to re-adjust the 5 volts coming from the controller through the long cable.

7.0 Connection to Non-Newport Controllers

WARNING

Newport takes no responsibility for improper functioning or damage of a stage when it is used with any non- Newport controllers.

WARNING

Newport guarantees the “CE” compliance of the (M-)UTM translation stages only if they are used with Newport cables and controllers.

Nevertheless, the figure below indicates the recommended wiring when a (M-)UTM stage is used with non-Newport controllers.

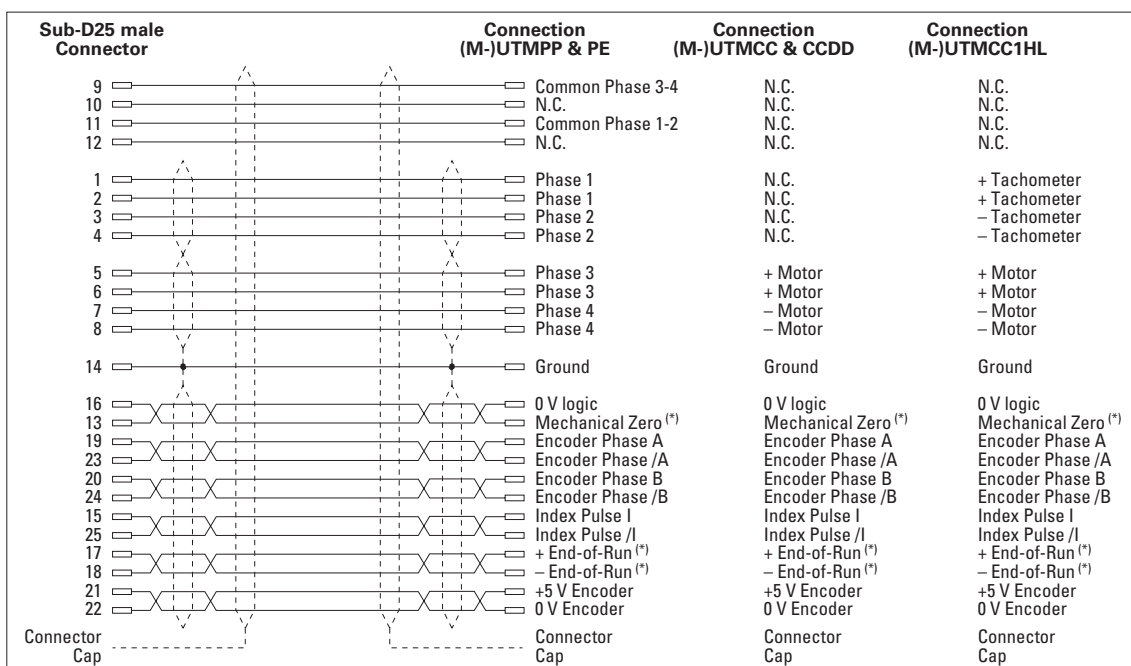

* Open collector type with a 5.6 V protective Zener diode.

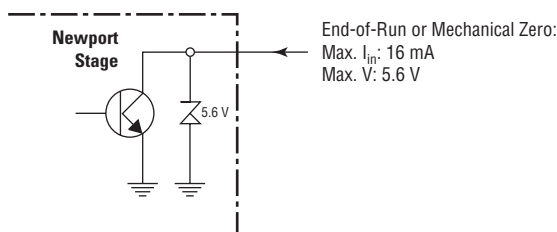

If the “Mechanical Zero” output is not used, a 1 kΩ/0.25 W resistor must be connected between pins #13 and #21.

“Encoder” and “Index Pulse” are “differential pair” type output signals. Using these signals permits a high immunity to noise. Emission circuits generally used by Newport are 26LS31 or MC3487. Reception circuits to use are 26LS32 or MC3486.

8.0 Mounting

8.1 Stage Mountings

WARNING

Before to use a (M-)UTM stage, it is imperative to fix it:

- directly on a rectified working surface, from holes located on the mounting plate,
 - on another stage, directly or with a mounting interface.
- but in no case, the stage has to remain without fastening.

It is equally necessary to fasten the device to move on the carriage:

- directly,
- removing the plate on the top of the stage.

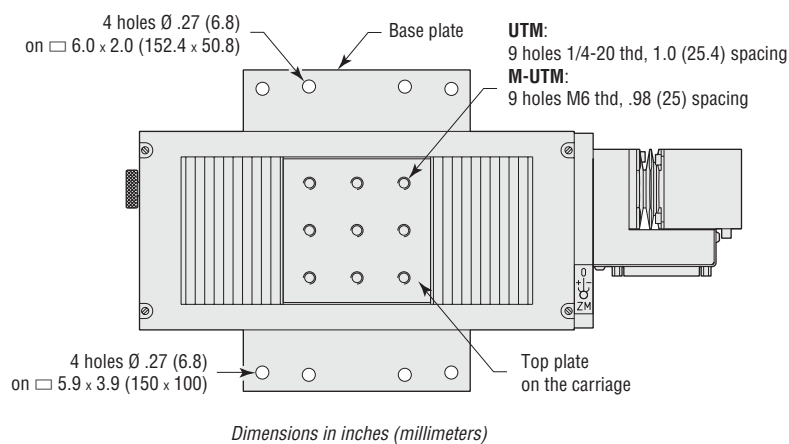

CAUTION

The working surface flatness directly influences stage accuracy and performance.

8.2 Interfaces Disassembling

- 1 Disassemble the top plate fixed on the carriage of the stage with 4 CHc M4 x .39 in. (10 mm) screws / \square 2.48 in. (63 mm).

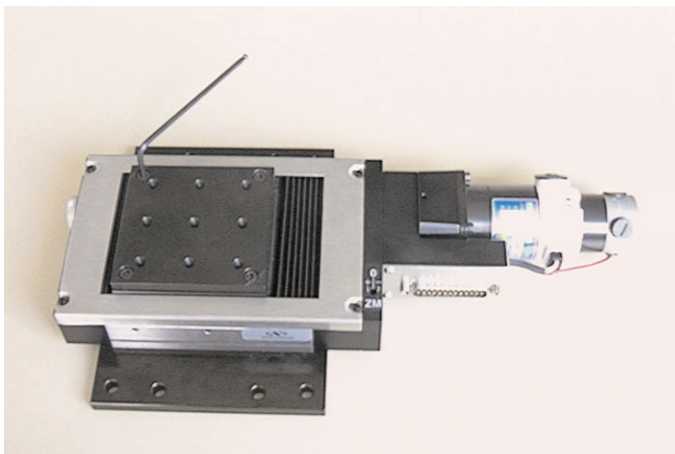

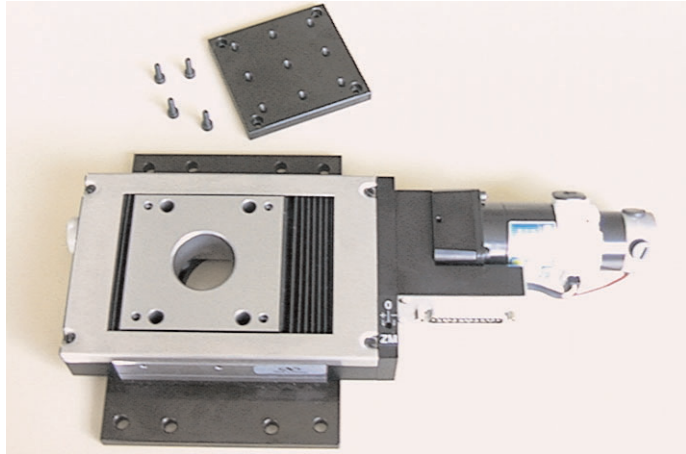

② Turn the stage upside down.

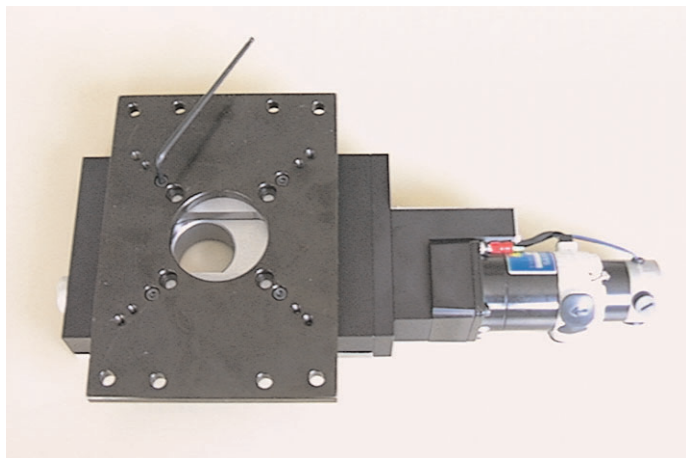

③ Disassemble the base plate fixed on the body of the stage with 4 CHc M4 x .39 in. (10 mm) screws / □ 2.48 in. (63 mm).

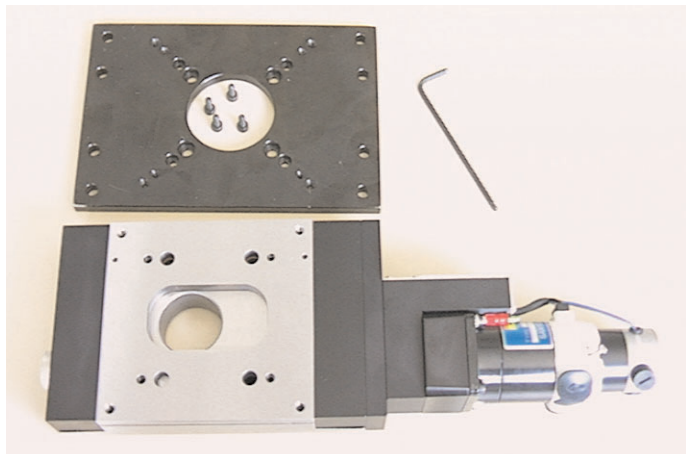

8.3 Mounting on Working Surface

- ❶ Rotate the manual knob to move the carriage to provide access to the 2 holes on the bottom of the stage.

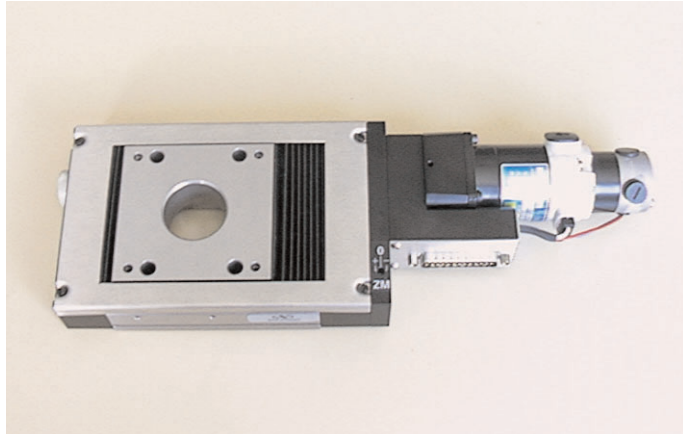

- ❷ Fasten the stage on the working surface with 2 M-CAP-M41 captive screws.
- ❸ Move the carriage to access the other 2 holes on the bottom of the stage.
- ❹ Fasten the stage on the working surface with 2 M-CAP-M41 captive screws.

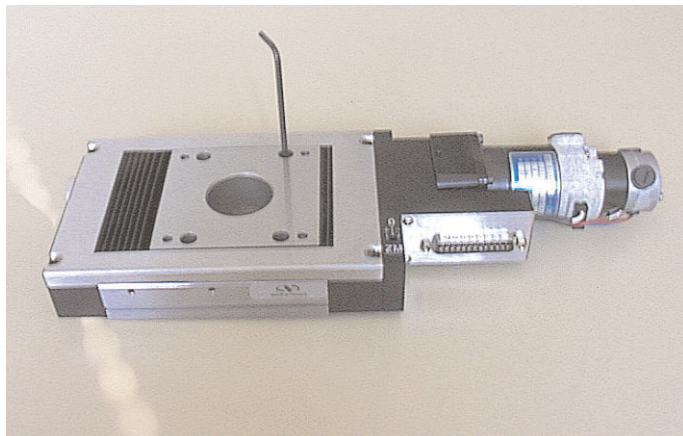

CAUTION

To fasten (M-)UTM stages, use only M-CAP-M41 captive screws, especially devised.

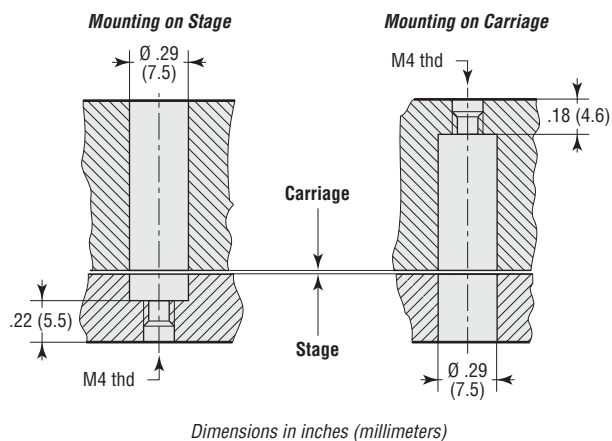

CAUTION

When mounting (M-)UTM stage on working surface, the depth of the M4 threaded holes of the working surface must be deeper than 8 mm. Protruding captive screws will damage the carriage.

Before power on motor stage, make a displacement try with the knurled knob, to verify that the displacement of the carriage is correct.

8.4 Assembling by the Carriage

Make steps of “Mounting on Working Surface” chapter in the same order.

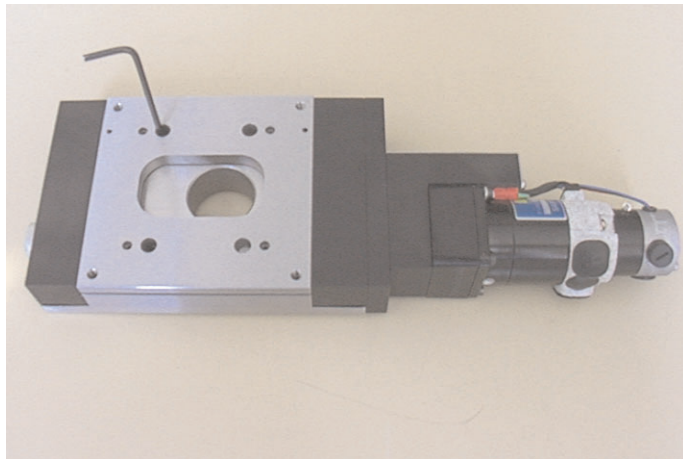

8.5 Disassembling

Make steps of “Mounting on Working Surface” chapter in the opposite order.

8.6 Interface Plates Mounting

Make steps of “Interfaces Disassembling” chapter in the opposite order.

8.7 Assembly Pattern

Stacking (M-)UTM Series stages either together or with other Newport stage is easily accomplished. Below are example schematics of the assembly patterns used. These interfaces are accessed by unscrewing and removing the upper and/or lower plates of the stages (see dimension drawing).

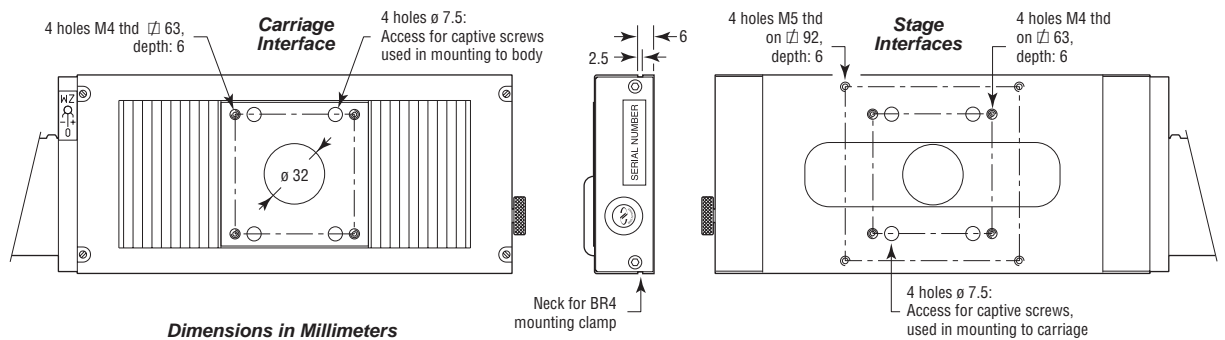

9.0 Dimensions

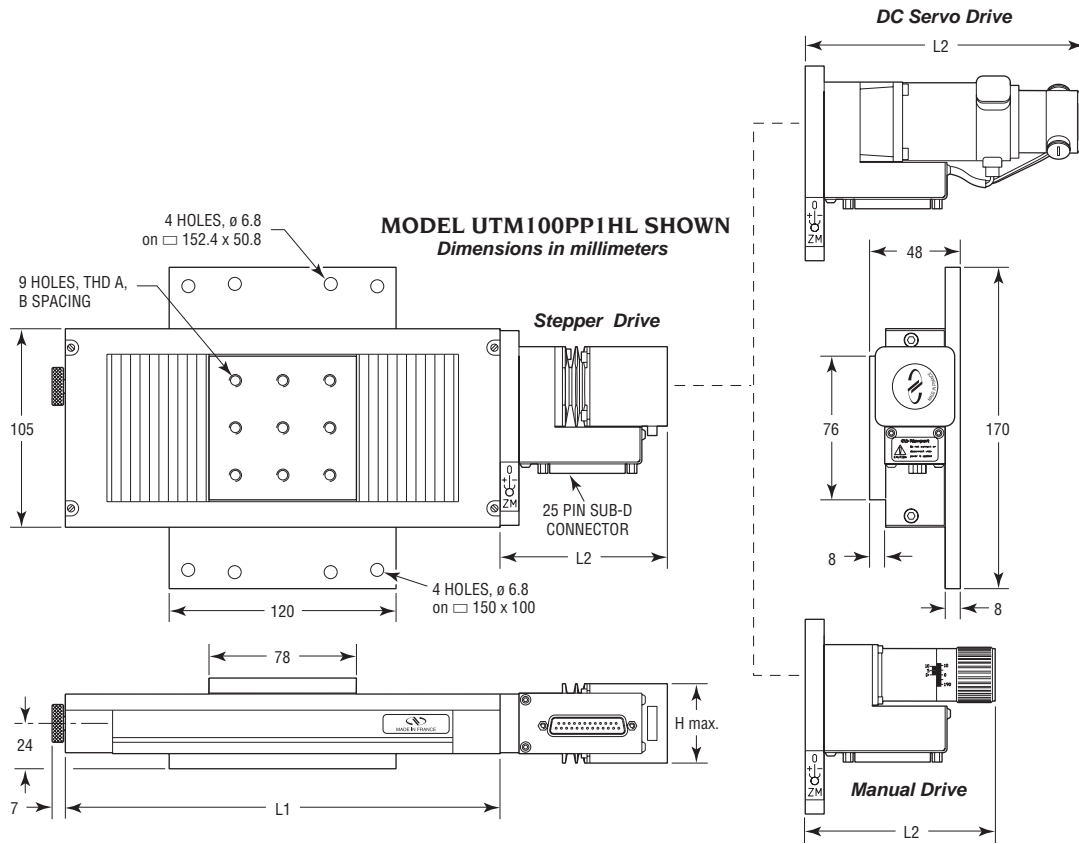

Model (Metric)	Thread	Dimension [in. (mm)]	
	A	B	
UTM (M-UTM)	1/4-20 (M6)	1.0 (25)	

Travel [in. (mm)]	.98 (25)	1.97 (50)	3.9 (100)	5.9 (150)
L1 [in. (mm)]	6.1 (155)	7.1 (180)	9.1 (230)	11.0 (280)

UTM (M-UTM)	Dimension [in. (mm)]	
	L2	H
MS1	4.0 (100.5)	1.26 (32)
MS.1	5.6 (141.5)	1.26 (32)
PP1HL	3.6 (90.5)	1.65 (42)
PP.1	5.2 (131.5)	1.65 (42)
PE1	5.5 (139)	1.26 (32)
PE.1	7.1 (180)	1.26 (32)
CC.1	5.2 (133)	1.91 (48.5)
CC1HL	5.8 (148)	1.91 (48.5)
CC1DD	4.6 (116.5)	1.26 (32)
CC.1DD	6.2 (157.5)	1.26 (32)

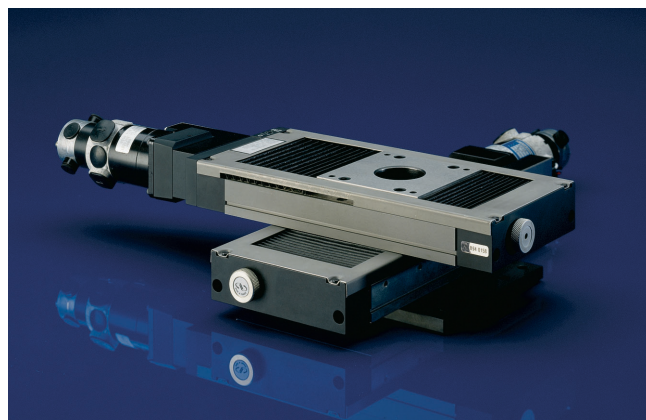

(M-)UTM Series XY assemblies are an economical choice when precision motion for light loads is required. These stages can be aligned to within 50 μ rad orthogonality.

10.0 Accessories: EQ100 Brackets

EQ100 Series right-angle brackets (to order separately) can be used for vertical mounting configurations of a (M-)UTM stage.

Model	Dimension [in. (mm)]		
	A	B	C
EQ100-S	5.3 (135)	5.1 (130.5)	4.1 (105)
EQ100-L	8.5 (215)	5.9 (144)	6.9 (174)

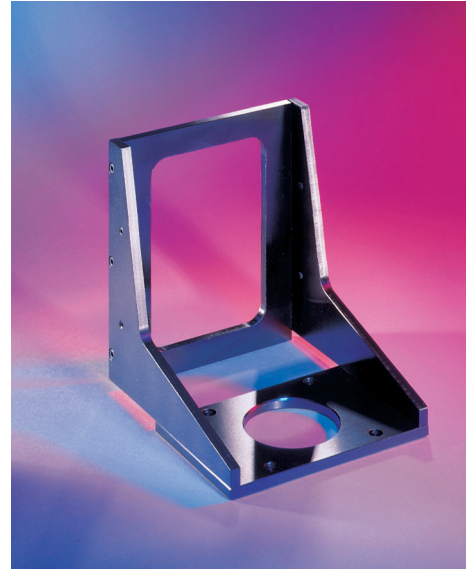
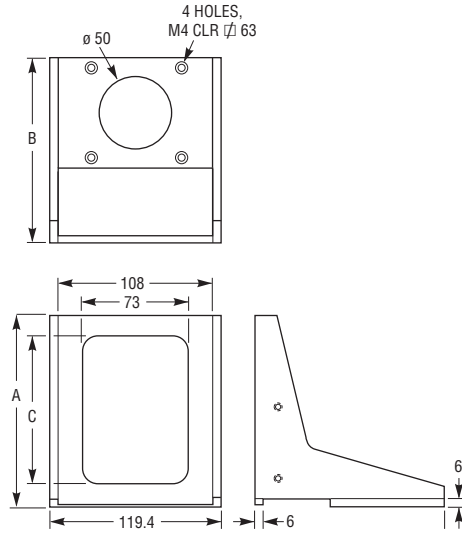

Dimensions in millimeters.

Model	Description
EQ100-S	Right-Angle Bracket for (M-)UTM25/50
EQ100-L	Right-Angle Bracket for (M-)UTM100/150



(M-)UTM X-Z assemblies can be aligned to within 50 μ rad orthogonality and can provide up to 150 mm of travel.

11.0 Maintenance

RECOMMENDATION

It is recommended to contact our After Sales Service which will be able to define the appropriate maintenance for your application.

11.1 Maintenance

The (M-)UTM stage requires no particular maintenance. Nevertheless, this is a precision mechanical device that must be kept and manipulated with precaution.

PRECAUTIONS

The (M-)UTM stage must operate, and be stocked in a clean environment, without dust, humidity, solvents or other substances.

RECOMMENDATION

It is recommended to return your stage to our After Sales Service after every 2000 hours of use for lubrication.

If your (M-)UTM stage is mounted on a workstation and cannot be easily dismantled, please contact our After Sales Service for further instructions.

11.2 Repairing

CAUTION

Never attempt to disassemble an element of the stage that has not been specified in this manual.

Disassembling a non specified element can cause a malfunction of the stage.

If you observe a malfunction in your stage, please immediately contact us to make arrangements for a repair.

CAUTION

All disassembly attempts or repair of stage without authorization will void your warranty.

11.3 Calibration

CAUTION

It is recommended to return your stage to Newport once a year for a recalibration to its original specifications.

(M-)UTM

**Mid-Range Travel
Steel Linear Stages**



Newport.

CE Declaration of Conformity

We declare that the accompanying product, identified with the “CE” mark, meets all relevant requirements of Directive:

- 73/23/CEE, for Low Voltage Compatibility.
- 89/336/EEC for Electromagnetic Compatibility.

Compliance was demonstrated to the following specifications:

EMISSION:

Radiated and Conducted Emission in accordance with relative prescription to the EMC, NF EN61326-1: Standards for measurement, lab and control equipment.

IMMUNITY:

Radiated and Conducted Immunity in accordance with relative prescription to the EMC, NF EN61326-1: Standards for measurement, lab and control equipment.

SAFETY:

CEI 1010-1, safety standards for measurement, lab and control equipment.

Jean-Marc DELAHAYE
Quality Director
Zone Industrielle
45340 Beaune-la-Rolande, France